

ASU Biological Safety Manual

I. Foreword

The Biological Safety Manual (or Biosafety Manual) has been adopted by Arizona State University to be a resource for information, guidelines, policies, and procedures that will enable safe research and to help eliminate, or reduce, the potential for exposure to biohazards. The Department of Environmental Health and Safety (EHS) developed this manual to help ensure compliance with the following federal, state, and local regulations and guidance materials:

- 18 United States Code § 175b
- 29 Code of Federal Regulations § 1910.1030
- 42 Code of Federal Regulations § 1003
- 42 Code of Federal Regulations § 71.54
- 42 Code of Federal Regulations § 72-73
- 49 Code of Federal Regulations, § 171-180
- 7 Code of Federal Regulations § 331
- 9 Code of Federal Regulations § 121
- Arizona Administrative Code, Article 14, Biohazardous Medical Waste and Discarded Drugs
- Arthropod Containment Guidelines, Version 3.2.
- Centers for Disease Control and Prevention and National Institutes of Health, “Biosafety in Microbiological and Biomedical Laboratories, 6th Edition.”
- Department of Health and Human Services, “Guide for the Care and Use of Laboratory Animals, 8th edition.”
- National Institutes of Health, “Guidelines for Research Involving Recombinant or Synthetic Nucleic Acid Molecules”
- Public Act 107-188, HR3448
- United States Department of Agriculture, or USDA permitting requirements

The ASU Biosafety Manual provides a compilation of suggested work practices, protocols, and systems to work safely at ASU. The ASU Biosafety Manual should not be considered the only reference for health and safety concerns. It is intended that the principal investigator and supervisory personnel will supplement this information with instruction and guidance regarding specific practices and procedures unique to the work being done in their areas by completing a lab-specific biosafety manual and including all relevant documentation available to laboratory users. In addition, EHS is always available to address health and safety concerns. The ASU Biosafety Manual is reviewed at least annually by EHS and the Institutional Biosafety Committee and was last approved on **December 1, 2021**.

Signatures:

DocuSigned by:



D4FA3D072DC346A...
David Gillum, Assistant Vice President
Chief Safety Officer and CDC Responsible Official
Environmental Health and Safety

DocuSigned by:



B932A42E9D04430...
Debra Murphy, Director
Institutional Official
Knowledge Enterprise

DocuSigned by:



A72035543C464DB...
Bertram Jacobs PhD, Professor
Chair, Institutional Biosafety Committee
Center for Immunotherapy, Vaccines and Virotherapy

DocuSigned by:



E81D4000B0B9480...
Irene Mendoza, MS, RBP
Institutional Biosafety Officer
Sr. Safety Partner, Biosafety and Biosecurity
Environmental Health and Safety

DocuSigned by:



307B4829B603270...
Gregory L. Powell, PhD
Animal Biosafety Officer
Sr. Safety Partner, Animal Biosafety
Environmental Health and Safety

Table of Contents

I.	Foreword	2
II.	Introduction	7
III.	Biosafety oversight	8
IV.	Roles and responsibilities	9
	A. Arizona State University.....	9
	B. Institutional Biosafety Committee.....	9
	C. Biosafety in Animal Use	10
	D. Environmental Health and Safety and ASU Biological Safety Officer	10
	E. ASU Employee Health	11
	F. Principal Investigator	11
	G. Laboratory personnel	13
	H. Responsible Official	13
	I. Other organizations	14
	J. Visitors, vendors, and contractors	14
V.	Incident reporting	15
	A. Reportable incidents and violations	15
	B. Principal Investigator responsibilities	15
	C. Biological Safety Officer responsibilities.....	15
	D. Institutional responsibilities	15
	E. Institutional Official responsibilities.....	16
VI.	Risk Group classifications	17
VII.	Biological Safety Levels	18
VIII.	Animal Biological Safety Levels	20
IX.	Arthropod Containment Levels.....	23
X.	Training for working safely with biohazards	25
XI.	Biohazardous research project registration.....	26
	A. Select agents and toxins.....	26
	B. Toxins of biological origin	26
	C. Human blood and tissue	27
	D. Recombinant and synthetic nucleic acid molecules	27
	E. Environmental samples.....	27
XII.	Controlled substances	28
XIII.	Animal research project registration.....	30
	A. Vertebrate Animals	30
	B. Arthropod Research Project Registration.....	30

	XIV.	Field research project registration	31
XV.		Biohazardous waste	32
XVI.		Animal waste	33
XVII.		Biohazardous waste handling	34
XVIII.		Laboratory procedures and equipment	35
	A.	Exposure control	35
	B.	Biological safety cabinets, or BSC	36
	C.	Steps for working in a biological safety cabinet	37
	D.	Certification of the biological safety cabinet	38
	E.	Decontamination	39
	F.	Decontamination in animal facilities	40
XIX.		Animal hazards and exposures	41
	A.	Bites and scratches	41
	B.	Physical hazards	41
	C.	Chemical hazards	42
	D.	Animal allergies	42
	E.	Latex gloves and related allergies	43
XX.		Zoonoses	45
	A.	Rodents	45
	B.	Gerbils, hamsters, and other small rodents	46
	C.	Laboratory rabbits	46
	D.	Birds	46
	E.	Dogs and cats	47
	F.	Fish, corals, and amphibians	47
	G.	Reptiles	47
	H.	Livestock	48
	I.	Non-Human Primates, or NHPs	48
XXI.		Emergency response procedures	50
	A.	Exposures to biohazards	50
	B.	Spills of biohazards (including r/sNA molecules)	51
	C.	Spills of biohazards inside a biological safety cabinet	51
	D.	Small spills (<500 mL) of biohazards outside a biological safety cabinet	52
	E.	Large spill (>500 ml) of biohazards outside a biological safety cabinet	52
	F.	Spill of biohazards in a centrifuge	53
	G.	Reporting exposures	53
XXII.		Permits	54
	A.	CDC Import Permit Program	54

B.	USDA Animal and Plant Health Inspection Service (APHIS) Permits	54
C.	Invasive species in Arizona	55
D.	U.S. Fish & Wildlife Service Permits	55
E.	Agreements with ASU	57
XXIII.	Transfers, packaging, and shipping of biological materials	58
A.	Transfers.....	58
B.	Packaging	58
C.	Packaging volumes	59
D.	Packaging with dry ice	60
E.	Labeling	60
F.	Shipping and transportation methods and requirements	60
G.	Other permits.....	62
XXIV.	Food and beverages in the laboratory	63
XXV.	Nails and jewelry	64
XXVI.	Protective clothing beyond the laboratory	65
XXVII.	Laundering laboratory clothing	66
A.	ASU laundry facilities	66
B.	Professional laundering services	66
C.	Laundering of personal clothing.....	66
D.	Overtly contaminated clothing	66
E.	ASU Lab Coat Laundering Program	66
XXVIII.	Safety audits	67
XXIX.	Security.....	68
XXX.	Working alone	69
XXXI.	Recordkeeping.....	70
XXXII.	Program evaluation	71
	Appendix A - Definitions	72
	Appendix B - Acronyms	74
	Appendix C - Disinfection Tables.....	75
	Appendix D - Serum storage procedures.....	78

II. Introduction

Biosafety encompasses the knowledge, techniques, equipment and facilities necessary to prevent or minimize an exposure to, or release of, a biohazard. The mission of the EHS Biosafety group is to assure a safe and healthy environment for individuals working with biohazards and to protect the community and environment by preventing the release and exposure to biohazards.

The Arizona State University, or ASU, Biosafety Manual is intended to be a resource for information, guidelines, policies and procedures that will enable and encourage safe research and to eliminate, or reduce, the potential for exposure to biohazards. The information presented here also reflects the requirements and guidelines of federal and state regulations. The most current version of the Biosafety Manual will be maintained on the [EHS Biosafety and Biosecurity](#) website.

The ASU Biosafety Manual is applicable to all laboratory, research, teaching and support activities that may involve biohazards. Biohazards are microorganisms, microbial toxins or other biological agents that can infect and/or cause disease in humans, animals, or plants. Biohazards may include bacteria, bacterial toxins, viruses, fungi, rickettsia, prions, protozoans, parasites, genetically modified organisms, recombinant, or synthetic nucleic acid molecules. In addition, biohazards include human blood, body fluid, tissues, and cell lines of human origin. Biohazards are often referred to as infectious agents or etiological agents.

All research disclosures must be reviewed and approved by the Institutional Biosafety Committee, or IBC, prior to beginning work if they involve the use of any of the following:

- Agents that can infect and/or cause disease in humans, animals, or plants.
- Archaeological samples (e.g., bones, clothing fragments and pottery).
- Biohazardous waste.
- Environmental/field samples (e.g., water, wastewater, soil, and air samples).
- Experimentally infected animals and those naturally harboring zoonotic infectious agents.
- Genetically modified organisms.
- Human cell lines and other materials of human origin.
- Recombinant and synthetic nucleic acid molecules.
- Select agents and toxins.
- Transgenic plants and animals.

For information about field work, please refer to ASU's [Field Research Safety Manual](#).

ASU is required to have an occupational health and safety program that addresses potential hazards associated with the conduct of animal research. The publication by the Institute for Laboratory Animal Research (ILAR), [Occupational Health and Safety in the Care and Use of Research Animal](#), is most helpful in this regard. Additional safety guidance for working with non-human primates is available in the ILAR publication, [Occupational Health and Safety in the Care and Use of Nonhuman Primates](#).

III. Biosafety oversight

Guidance documents from the National Institutes of Health, or NIH, and the Centers for Disease Control and Prevention, or CDC, form the basis for the biosafety practices included in this manual. There are additional guidance documents and regulations imposed by various funding agencies that individual principal investigators must be aware of and incorporate into a [Laboratory-Specific Biosafety Manual](#). Biosafety requirements must be followed to ensure the continuation of grant funding from federal agencies and for health and safety purposes.

The [NIH Guidelines for Research Involving Recombinant or Synthetic Nucleic Acid Molecules](#), or NIH Guidelines, detail procedures and practices for the containment and safe conduct of various forms of recombinant or synthetic nucleic acid research. The NIH Guidelines:

- Establish the practices, procedures, and conditions under which recombinant and synthetic nucleic acid activities must be conducted.
- Mandate the establishment of an Institutional Biosafety Committee for the review and oversight of biological research.
- Outline roles and responsibilities for biosafety.

All institutions, including ASU, receiving NIH funding for recombinant or synthetic nucleic acid molecules activities must comply with the NIH Guidelines. Researchers at institutions that are subject to the NIH Guidelines must comply with the requirements even if NIH does not fund the individual project. **Non-compliance with the NIH Guidelines may result in suspension, limitation, or termination of financial assistance** for the research project and of NIH funds for other recombinant or synthetic nucleic acid activities at ASU or the requirement for prior NIH approval of any and/or all recombinant or synthetic nucleic acid projects at ASU.

The CDC/NIH manual, [Biosafety in Microbiological and Biomedical Laboratories](#), or BMBL, describes the appropriate measures and facilities for work with all microbial agents, including bacterial, viral, parasitic, rickettsial and prion agents as well as toxins of biological origin.

The requirements described in the Occupational Safety and Health Administration's, or OSHA, [Bloodborne Pathogens regulation](#) (29 CFR § 1910.1030) apply to work with human blood, tissue, organs, body fluids and cell cultures. Special training, medical surveillance, procedures and equipment that must be in place for protection against bloodborne pathogens, needle sticks and other sharps injuries, are described in the ASU [Exposure Control Plan](#).

Handling and disposal of biohazardous waste is also regulated by OSHA under the OSHA Bloodborne Pathogens regulation and by state and federal statutes. The procedures for biohazardous waste handling are described in the ASU [Biological Waste Handling Procedures](#).

The requirements for packaging and shipment of biohazards are provided in the Department of Transportation's [hazardous materials regulation](#) 49 CFR § 171-180. In addition, permits may be required to ship biological materials. Please refer to the CDC [Etiological Agent Import Permit Program](#) and the Animal and Plant Health Inspection Service, APHIS, [permit program](#), [U.S. Fish and Wildlife Service Permits](#), [Food and Drug Administration Permits](#), and [National Park Service Permits](#). In addition, country-specific or state-specific permits may be required. Contact the [ASU biosafety team](#) for assistance with permits. Information on shipping procedures that comply with these regulations is found in the section on "Shipping and Transportation Methods and Requirements" in this manual.

Specific requirements for handling biological toxins are found in the BMBL and OSHA's [Occupational Exposure to Hazardous Chemicals in Laboratories](#), standard 29 CFR § 1910.1450. Information regarding ASU's radiation safety program is found in the ASU Radioactive Materials Manual.

IV. Roles and responsibilities

The biological safety program at ASU developed from the University's commitment to address and comply with regulations and recommendations for biosafety and biosecurity, as well as the health and safety of the staff, researchers, community, and environment. The Institutional Biosafety Committee and the ASU Department of Environmental Health and Safety provide oversight of ASU's biological safety program.

Roles and responsibilities for biosafety and biosecurity are included in this section.

A. Arizona State University

ASU has instituted and maintains a biosafety program for personnel who may be exposed to biological hazards (biohazards) during the performance of their duties. The biosafety program is designed to achieve regulatory compliance and to provide a means for employees to be informed about and protected from biohazards. To maintain regulatory compliance and to protect personnel from biohazards, Arizona State University must:

- Appoint a Biological Safety Officer for the institution.
- Ensure appropriate training is provided to personnel conducting research with biohazards or recombinant or synthetic nucleic acid materials.
- Ensure that research conforms to the provisions of the *NIH Guidelines*.
- Establish an Institutional Biosafety Committee.
- Establish and maintain a health surveillance program for personnel.
- Implement policies for safe conduct of biological and recombinant or synthetic nucleic acid research.
- Report any significant problems, violations or significant research-related accidents or illnesses to the NIH Office of Biotechnology Activities within 30 days.

B. Institutional Biosafety Committee

The committee is charged with review, approval and oversight of research involving recombinant or synthetic nucleic acid molecules and biohazards in research and teaching activities. Biohazards are microorganisms, microbial toxins, or other biological agents that can infect and/or cause disease in humans, animals, or plants. Biohazards may include bacteria, bacterial toxins, viruses, fungi, rickettsia, prions, protozoans, parasites, genetically modified organisms, or r/sNA molecules. In addition, biohazards include human blood, body fluid, tissues, and cell lines of human origin. Biohazards are often referred to as infectious agents or etiological agents.

Responsibilities of the Institutional Biosafety Committee include assessment of facilities in collaboration with EHS, procedures, practices, and training of research personnel to assure compliance with NIH Guidelines and other pertinent guidelines and regulations.

To successfully carry out these responsibilities, the Institutional Biosafety Committee is appointed to achieve sufficient knowledge and expertise in biomedical research and biosafety. The Institutional Biosafety Committee has the authority to approve, require modifications to secure approval, disapprove, suspend, or terminate research activities as required to assure compliance with applicable regulations and guidelines. For more information about the ASU Institutional Biosafety Committee, please visit researchintegrity.asu.edu/biosafety/forms.

C. Biosafety in Animal Use

Approval by the Institutional Biosafety Committee and the [Institutional Animal Care and Use Committee](#) (IACUC) is required for any animal use that may create biohazards for personnel or the environment; use of infectious agents, recombinant or synthetic nucleic acids with animals; or any use of non-human primates and field animals with known zoonotic potential.

However, the animal room can present some unique challenges. In the microbiological laboratory, hazardous conditions are caused by personnel or by the equipment being used. In the animal room, the activities of the animals themselves can present additional hazards. Animals may generate aerosols; they may bite, and scratch and they may be infected with a zoonotic agent.

ASU is required to have an Occupational Health Program to support the academic, research and operational activities of the animal research program. The publication of the Institute of Medicine's, book titled, [Occupational Health and Safety in the Care of Research Animals](#), is a good resource.

Ideally, facilities for laboratory animals used in studies of infectious or noninfectious disease should be physically separate from other activities such as animal production, quarantine, and laboratories. Traffic flow that will minimize the risk of cross contamination should be considered in the plans.

D. Environmental Health and Safety and ASU Biological Safety Officer

The responsibilities of Environmental Health and Safety and the Biological Safety Officer include, but are not limited to, the following:

- Advise researchers on proper waste disposal methods based on federal and state regulations.
- Assist researchers in the development of plans for preventing and handling accidental spills and personnel contamination.
- Develop, implement, and maintain the university's biosafety program to address issues of biosafety and biosecurity.
- Develop, implement, and maintain the university's program for select agents and toxins.
- Perform and review the required risk assessment to determine appropriate biosafety level and personal protective equipment (PPE) for handling recombinant and synthetic nucleic acid molecules or biohazards.
- Investigate laboratory accidents involving recombinant and synthetic nucleic acid molecules and biohazards.
- Perform periodic inspections to ensure that laboratory standards are rigorously followed.
- Promote regulatory compliance and a safe laboratory environment.
- Provide advice on laboratory security.
- Provide oversight of the ASU Bloodborne Pathogen Program and conduct training for laboratory personnel with such exposure.
- Provide technical advice to principal investigators and the Institutional Biosafety Committee on research safety procedures.
- Provide training and resources for the safe use and practices for those working with potential biohazards, and laboratory equipment.
- Report to the Institutional Biosafety Committee and the institution any significant problems, violations of the NIH Guidelines, and any significant research-related

accidents or illnesses of which the Biological Safety Officer becomes aware.

The Biological Safety Officer has the authority to immediately halt research that he/she deems to be an immediate threat to safety of personnel, environment, or the community at large. The Biological Safety Officer must report such action to the Institutional Biosafety Committee immediately.

E. ASU Employee Health

ASU Employee Health leads a culture of occupational safety for the ASU community by providing high quality, cost-efficient healthcare and promoting the health, safety and well-being of ASU employees.

The responsibilities of ASU Employee Health include, but are not limited to, the following:

- Provide medical reviews of annual questionnaires for individuals with direct or frequent contact with vertebrate animals, allergens, unfixed tissue or bodily fluids.
- Provide occupational medical exposure risk assessments for with exposures to biological, chemical, noise, laser, and radiological agents.
- Provide pre-placement or post-job offer, physical examinations.
- Provide job placement assessments, periodic examinations, and maintenance of confidential employee health records, including individual screening results.
- Administer the medical evaluations related to biological exposures
- ASU Employee Health administers occupational health services for personnel. Services are under the guidance of the [ASU Institutional Animal Care and Use Committee](#).
- Provide immunizations for individuals as required for occupational exposures
- Provide medical monitoring as required based upon risk assessment
- Provide medical guidance for post exposure protocols, the select agent program and recombinant nucleic acid exposures
- Oversight to the ASU Serum banking program

F. Principal Investigator

A scientist trained and knowledgeable in appropriate laboratory techniques, safety procedures and hazards associated with handling biohazards must be responsible for the conduct of work with any biohazards or materials. This individual should consult with biosafety or other health and safety professionals regarding risk assessment. Responsibilities of the principal investigator include:

- Accept direct responsibility for the health and safety of those working with animals, biohazardous materials and/or select agents and toxins.
- Adhere to approved emergency plans for handling accidental spills and personnel contamination.
- Comply with permit and shipping requirements for recombinant or synthetic nucleic acid molecules, transgenic, or biohazards. This includes permits, material transfer agreements, and other documentation for international, interstate, and intrastate transport of genetically modified and biohazardous material.
- Develop specific biosafety standard operating procedures for animals and biohazards used in the laboratory.
- Ensure compliance by laboratory personnel with relevant regulations, guidelines, and policies.
- Ensure all appropriate personal protective equipment is provided and used.

- Ensure proper training, including refresher training, and instruction for laboratory personnel in safe practices and protocols, including, at a minimum, training in aseptic techniques and characteristics of the material(s) used. Please refer to the ASU [Laboratory-Specific Biosafety Training Checklist](#). These signed documents must always remain easily accessible in the laboratory.
- Ensure the integrity of the safety equipment (e.g., biological safety cabinets), maintain biological containment (e.g., purity and genotypic and phenotypic characteristics), and ensure correct procedures or conditions are followed to prevent a release of or exposure to recombinant or synthetic nucleic acid molecules and/or biohazards, select agents or toxins.
- Inform the laboratory staff of the Occupational Health and Safety Program, possible symptoms of illness relating to materials used, and provisions for any precautionary medical practices advised or required, such as vaccinations or serum collection.
- Propose appropriate microbiological practices and laboratory techniques to be used for the research.
- Provide to all laboratory staff the protocols that describe the potential biohazards and the precautions to be taken. Instruct, train, and supervise research personnel in:
 - Aseptic technique.
 - Characteristics of the material(s) used.
 - Laboratory practices and techniques required to ensure safety.
 - NIH classification of work (if working with r/sNA molecules).
 - Procedures for dealing with spills or potential exposures to the agents described in the research.
 - Signs and symptoms of biohazards.
- Obtain Institutional Biosafety Committee approval prior to initiating or modifying any research involving use of recombinant or synthetic nucleic acid molecules and/or biohazards and maintain that approval through timely submission of annual reviews.
- Immediately report any significant problems pertaining to the operation and implementation of containment practices and procedures in writing to the Biological Safety and any other university committees (e.g., Institutional Biosafety Committee, Institutional Review Board, Institutional Animal Care and Use Committee) that have reviewed and approved the research activity.
- Supervise laboratory staff to ensure that the required safety practices and techniques are employed. Correct work errors and conditions that may result in accidents, injuries, or the release of biohazards.

Principal Investigators are also responsible for full compliance with the NIH Guidelines during the conduct of recombinant or synthetic nucleic acid research.

- The PI will consult with the IBC to determine whether the recombinant or synthetic nucleic acid molecule research is subject to the NIH Guidelines.
- Develop specific biosafety standard operating procedures for recombinant or synthetic nucleic acid molecules or biohazards used in the laboratory.
- Obtain Institutional Biosafety Committee approval before initiating recombinant or synthetic nucleic acid molecule research subject to the NIH Guidelines.
- Make the initial risk assessment and determination of biological containment levels in accordance with the NIH Guidelines when registering research with the Institutional Biosafety Committee.
- Immediately report any significant problems, violations of the NIH Guidelines, or any significant research-related accidents and illnesses to the Biological Safety Officer, Greenhouse/Animal Facility Director, Institutional Biosafety Committee, NIH Office of Biotechnology Activities, and other authorities, as appropriate.
- Submit any subsequent changes (e.g., changes in the source of DNA or host-vector system) to the disclosure to the Institutional Biosafety Committee for review and

approval or disapproval.

G. Laboratory personnel

The responsibilities of animal care and laboratory personnel include but are not limited to the following:

- Complete any necessary medical surveillance.
- Follow all laboratory practices, protocols and comply with all applicable policies, procedures and guidelines.
- Fully comprehend all biohazards and select agents and toxins being used in the lab and the potential risks associated with exposure, as well as fully understanding the associated emergency response procedures.
- Obtain necessary and recommended vaccinations or submit declination forms as permitted.
- Participate in appropriate training and instruction to ensure that they are adequately trained and fully understand the instructions. This includes taking refresher courses as applicable.
- Report thefts, security incidents, accidents, spills, or contamination incidents to supervisor.

H. Responsible Official

A Responsible Official, or RO, is required under the Department of Health and Human Services, or HHS, and USDA [Select Agent and Toxin regulations](#). This individual's responsibilities can be found in the applicable regulations. Although this list is not intended to be a complete list, critical responsibilities include:

- Allow only approved individuals to have access to select agents or toxins.
- Conduct regular inspections, at least annually, of the laboratory where select agents or toxins are stored or used to ensure compliance with all procedures and protocols of this safety plan. The results of these inspections must be documented, and any deficiencies must be corrected and documented.
- Develop and implement safety, security, and emergency response plans.
- Maintain complete records relating to select agents as defined in 42 CFR 73.15.
- Provide appropriate training for safety, security, and emergency response.
- Provide immediate notice of any theft, loss, or release of a select agent or toxin.
- Provide proper laboratory facilities to contain and dispose of select agents and toxins.
- Report the identification of a select agent or toxin as a result of diagnosis, verification, or proficiency testing.
- Submit changes in the registration information by promptly notifying the CDC or Animal and Plant Health Inspection (APHIS)/USDA in writing. This includes modifications to the list of individuals that have been approved to work or access select agents, changes in work locations, and changes in protocols or objectives of the studies.
- Transfer select agents or toxins only to registered individuals.

The RO and primary contacts for ASU Select Agent Program are listed below:

- David Gillum, Assistant Vice President, Chief Safety Officer, EHS, RO
- Irene Mendoza, Sr. Safety Partner, Biological Safety Officer, EHS, ARO
- Amanda Rice, Associate Director of ASU Employee Health, EHS, ARO
- Giorgio Scarpellini, Safety Partner, EHS, ARO
- Gregory Powell, Sr. Safety Partner, Animal Biological Safety Officer, EHS, ARO

I. Other organizations

Other committees, including the Institutional Review Board, Radiation Safety Committee, and the Department of Public Safety must consult and coordinate with the Institutional Biosafety Committee and EHS on any proposals under their purview which involve the use of biohazards.

J. Visitors, vendors, and contractors

Contractors must ensure that appropriate personal protective equipment is available for their own workers. All visitors, vendors, and contractors must:

- Be accompanied by a Department of Justice approved person at all times while in areas with select agents or toxins.
- Comply with all security requirements and procedures.
- Use personal protective equipment provided for them by the laboratory or animal handling room.

V. Incident reporting

A. Reportable incidents and violations

Incidents or problems involving biohazards and/or recombinant or synthetic nucleic acid molecules must be immediately reported to the Biological Safety Officer. Examples of reportable significant incidents include but are not limited to any overt exposure, such as a needle stick, splash, and contamination due to equipment failure, and any potential exposure to biohazards. A significant event may also occur from a containment breach, which may be subsequently determined to pose either an overt or potential exposure to individuals.

It should be noted that waste from recombinant or synthetic nucleic acid molecule research is considered biohazardous and incidents involving improper disposal of recombinant or synthetic nucleic acid molecules must also be reported. Questions regarding reportable incidents should be directed to the Biological Safety Officer.

Failure by research personnel to follow federal and institutional regulations, guidelines, policies and/or procedures may also require reporting to the appropriate institutional, local, state and/or federal agencies. Violations may include but are not limited to conduct of new or ongoing research without appropriate federal or institutional registration, review, approval, or oversight.

B. Principal Investigator responsibilities

The principal investigator and their personnel must report any significant incident, violation of the NIH Guidelines, or any significant, research-related accidents and illnesses immediately by contacting the Biological Safety Officer. Examples of incidents and violations include:

- Any exposure (overt or potential) in a BSL-3 laboratory.
- Any illness that may be caused by the agents used in the laboratory.
- Any incident involving the improper disposal of recombinant or synthetic nucleic acid molecules.
- Overt exposures, which are defined as exposures that result in direct personnel exposure to biohazards such as injection, spills, splashes, or aerosol inhalation.
- Overt or potential exposures in BSL-1 or BSL-2 laboratories.
- Potential exposures, which are defined as exposures that have a high risk of exposing personnel to biohazards such as spills, containment failure while working with the agent or equipment failure that may produce aerosols.
- Injuries or exposures that require medical assistance must be reported within 8 hours. Fatalities must be reported immediately.

C. Biological Safety Officer responsibilities

The Biological Safety Officer is required, by the NIH Guidelines, to report to the Institutional Biosafety Committee:

- All violations of the NIH Guidelines and significant incidents.
- Any significant research-related accidents or illnesses.

D. Institutional responsibilities

The Institutional Biosafety Committee is required, by the NIH Guidelines, to report to the appropriate University official and to the NIH Office of Biotechnology Activities within 30

December 2021

Questions? Email biosafety@asu.edu or call 480-965-1823

Page 15

days any significant incidents, violations of the NIH Guidelines, or any significant research-related accidents and illnesses. The Institutional Biosafety Committee will be responsible to determine what actions, if any, are necessary. For example, the Institutional Biosafety Committee may choose to change the frequency of lab inspections, or change the biosafety level of the disclosure, based on results of the incident. Other Institutional Biosafety Committee reporting requirements (to the NIH Office of Biotechnology Activities and other agencies) include but are not limited to:

- Lax security, unsafe procedures used in a laboratory setting, improper disposal of recombinant waste.
- Research involving recombinant or synthetic nucleic acid molecules or biohazards without prior Institutional Biosafety Committee approval.
- Significant changes to proposed research risk without prior notification and approval by Institutional Biosafety Committee.

Some incidents must be reported to the NIH Office of Biotechnology Activities on an expedited basis. Spills or accidents in BSL-2 laboratories (involving recombinant or synthetic nucleic acid molecules) resulting in an overt exposure must be immediately reported to the NIH Office of Biotechnology Activities. In addition, spills or accidents involving recombinant or synthetic nucleic acid molecules occurring in high containment (BSL-3 or higher) laboratories resulting in an overt or potential exposure must be immediately reported to the NIH Office of Biotechnology Activities. The Institutional Biosafety Committee will report to the Institutional Official, who, in turn will direct the reporting process to the NIH Office of Biotechnology Activities, any of the above-described incidents.

Institutional violations that will be reported to the appropriate college or department head may include, but are not limited, to:

- Failure to comply with institutional and federal regulations, guidelines, and policies.
- Lapses in disclosure approval.
- Unsafe work practices.

E. Institutional Official responsibilities

Upon receiving a report from the Institutional Biosafety Committee, the Institutional Official will directly report:

- Any significant research-related illness or accident that may be hazardous to the public health and cooperate with state and local public health departments.
- In writing, any problems with or violations (non-compliance) of the NIH Guidelines, or any significant incident, accidents, or illnesses related to recombinant or synthetic nucleic molecules, to the NIH Office of Biotechnology Activities within 30 days or immediately for overt exposure to a BSL-2 agent or potential/overt exposure to a BSL-3 agent.

VI. Risk Group classifications

According to the CDC/NIH document, Biosafety in Microbiological and Biomedical Laboratories, also known as the BMBL, the three primary hazardous characteristics associated with biological agents include:

- The availability of preventive measures and effective treatments for the disease.
- The capability of an agent to infect and cause disease in a susceptible human or animal host.
- The virulence of an agent as measured by the severity of disease.

By taking the route of transmission of the disease into consideration, a standardized methodology was developed to classify biological agents into four different risk groups (see [Table 1](#)). Knowing the risk group of an agent assists researchers and safety professionals in determining the appropriate safety protocols to be followed.

Table 1. Risk Group (RG) classifications			
RG-1	RG-2	RG-3	RG-4
Agents not associated with disease in healthy adult humans.	Agents associated with human disease which is rarely serious and for which preventive or therapeutic interventions are often available.	Agents associated with serious or lethal human disease for which preventive or therapeutic interventions may be available (high individual risk but low community risk).	Agents that are likely to cause serious or lethal human disease for which preventive or therapeutic interventions are not usually available (high individual risk and high community risk).

VII. Biological Safety Levels

CDC and NIH have established four levels of biosafety, based on the degree of hazard associated with a microbial agent, to describe the combination of laboratory practices and techniques, safety equipment, and facilities needed to protect against exposure. The [CDC/NIH BMBL](#) outlines four different biological safety levels that are appropriate for the operations performed in a laboratory, the documented or suspected routes of transmission of the biological agent, and the laboratory function or activity. These four biosafety levels, or BSLs, require successively more stringent practices and facilities as work moves from the least restrictive, BSL- 1, to work with the highest hazard level of BSL-4. Exposure to biohazards may be prevented or limited by establishing and following the appropriate biosafety level practices and conditions. The requirements for each laboratory biosafety level can be found in the CDC/NIH BMBL.

The following bullets provide a summary of the four biological safety levels:

- **BSL-1** is required for work involving well-characterized agents not known to consistently cause disease in immunocompetent adult humans, and present minimal potential hazard to laboratory personnel and the environment.
- **BSL-2** is required for work involving agents associated with human disease and pose moderate hazards to personnel and the environment.
- **BSL-3** is required for clinical, diagnostic, teaching, research, or production facilities where work is performed with indigenous or exotic agents that may cause serious or potentially lethal disease through the inhalation route of exposure.
- **BSL-4** is required for work with dangerous and exotic agents that pose a high individual risk of aerosol-transmitted laboratory infections and life-threatening disease that is frequently fatal, for which there are no vaccines or treatments, or a related agent with unknown risk of transmission.
Note: No research with biohazards at BSL-4 is currently permitted in ASU facilities.

Personal protective equipment varies depending upon the biological safety level. Please refer to the table below for specific requirements for each of the four biological safety levels.

Table 2. Biological Safety - Personal Protective Equipment Requirements*

BSL-1	BSL-2	BSL-3	BSL-4
<ul style="list-style-type: none"> • Protective laboratory coats, gowns, or uniforms are worn to prevent contamination of personal clothing. • Protective eyewear worn when conducting procedures that have the potential to create splashes and sprays of microorganisms or other hazardous materials. Eye protection and face protection are disposed of with other contaminated laboratory waste or decontaminated after use. • Personnel who wear contact lenses in laboratories should also wear eye protection. • Gloves must be worn to protect hands from exposure to hazardous materials. 	<ul style="list-style-type: none"> • Protective laboratory coats, gowns, or uniforms designated for laboratory use are worn while working with hazardous materials and removed before leaving for non-laboratory areas. Protective clothing is disposed of appropriately or deposited for laundering by the institution. Laboratory clothing is not taken home. • Eye protection and face protection (e.g., safety glasses, goggles, mask, face shield or other splatter guard) are used for manipulations or activities that may result in splashes or sprays of infectious or other hazardous materials. Eye protection and face protection are disposed of with other contaminated laboratory waste or decontaminated after use. • Personnel who wear contact lenses in laboratories should also wear eye protection. • Gloves must be worn to protect hands from exposure to hazardous materials. • The risk assessment considers whether respiratory protection is needed for the work with hazardous materials. If needed, relevant staff are enrolled in a properly constituted respiratory protection program. • If research animals are present, a risk assessment considers appropriate eye, face, and respiratory protection, as well as potential animal allergens. 	<ul style="list-style-type: none"> • Protective clothing with a solid-front, such as tie-back or wrap-around gowns, scrub suits, or coveralls is worn. Protective clothing is not worn outside of the laboratory. Reusable clothing is decontaminated before being laundered. Clothing is changed when contaminated. • Eye protection and face protection (e.g., safety glasses, goggles, mask, face shield or other splash guard) are used for manipulations or activities that may result in splashes or sprays of infectious or other hazardous materials. Eye protection and face protection are disposed of with other contaminated laboratory waste or decontaminated after use. • Personnel who wear contact lenses in laboratories must also wear eye protection. • Gloves must be worn to protect hands from exposure to hazardous materials. • Two pairs of gloves are worn when appropriate. • Respiratory protection is considered. Staff wearing respiratory protection are enrolled in a properly constituted respiratory protection program. • Shoe covers are considered. If research animals are present, a risk assessment considers appropriate eye, face, and respiratory protection, as well as potential animal allergens. 	<ul style="list-style-type: none"> • Not permitted at ASU. • Please refer to the CDC/NIH document, "Biosafety in Microbiological and Biomedical Laboratories" for PPE requirements.

* Safety is improved when PPE is used in combination with physical containment devices or equipment, such as biological safety cabinets, or BSCs. Additional PPE may be required as determined by risk assessment.

VIII. Animal Biological Safety Levels

Similar to the BSL, there are four animal biosafety levels, or ABSL. These four animal biosafety levels are required for the use of experimentally infected animals housed in indoor research facilities (e.g., vivaria), and in the maintenance of laboratory animals that may naturally harbor zoonotic infectious agents.

As a general principle, the biosafety level (facilities, practices, and operational requirements) recommended for working with infectious agents *in vivo* and *in vitro* are comparable.

The four animal biosafety levels provide increasing levels of protection to personnel and to the environment and are recommended as minimal standards for activities involving infected laboratory animals. The four ABSLs describe animal facilities and practices applicable to work with animals infected with agents assigned to Biosafety Levels 1-4, respectively. Investigators that are inexperienced in conducting these types of experiments should seek help in designing their experiments from individuals who are experienced in this special work.

The following bullets provide a summary of the four animal biological safety levels:

- **ABSL-1** is required for work in animals involving well-characterized agents that are not known to cause disease in immunocompetent adult humans, and present minimal potential hazard to personnel and the environment.
- **ABSL-2** is required for work involving laboratory animals infected with agents associated with human disease and pose moderate hazards to personnel and the environment, and also addresses hazards from ingestion as well as from percutaneous and mucous membrane exposure.
- **ABSL-3** is required for work with laboratory animals infected with indigenous or exotic agents, agents that present a potential for aerosol transmission, and agents causing serious or potentially lethal disease.
- **ABSL-4** is required for work with animals infected with dangerous and exotic agents that pose a high individual risk of aerosol-transmitted laboratory infections and life-threatening disease that is frequently fatal, for which there are no vaccines or treatments, or a related agent with unknown risk of transmission. **Note: No research with biohazards at BSL-4 is currently permitted in ASU facilities.**

Personal protective equipment varies depending upon the biological safety level. Please refer to the following table for specific requirements for each of the four biological safety levels.

Table 3. Animal Biological Safety - Personal Protective Equipment (PPE) Requirements*

ABSL-1	ABSL-2	ABSL-3	ABSL-4
<ul style="list-style-type: none"> • Laboratory coats, gowns, or uniforms are the minimum recommended to prevent contamination of personal clothing. Protective outer clothing is not worn outside areas where infectious materials and/or animals are housed or manipulated. Gowns and uniforms are not worn outside the animal facility. • Eye protection and face protection (e.g., safety glasses, goggles, mask, face shield, or other splatter guard) are used for manipulations or activities that may result in splashes or sprays of infectious or other hazardous materials. Eye protection and face protection are disposed of with other contaminated facility waste or decontaminated after use. • Protective eyewear must be worn when conducting procedures that have the potential to create splashes of microorganisms or other hazardous materials. • Persons having contact with NHPs assess the risk of mucous membrane exposure and wear protective equipment (e.g., face shield, surgical mask, goggles), as appropriate. • Additional PPE is considered for persons working with large animals. • Gloves are worn to protect hands from exposure to hazardous materials and when handling animals. 	<ul style="list-style-type: none"> • Protective clothing, such as gowns, uniforms, scrubs, or laboratory coats, and other PPE are worn while in the areas where infectious materials and/or animals are housed or manipulated. • Scrubs and uniforms are removed before leaving the animal facility. • Reusable clothing is appropriately contained and decontaminated before being laundered. Animal facility and protective clothing is never taken home. • Disposable PPE and other contaminated waste are appropriately contained and decontaminated prior to disposal. • Eye protection and face protection (e.g., safety glasses, goggles, mask, face shield, or other splatter guard) are used for manipulations or activities that may result in splashes or sprays from infectious or other hazardous materials when the animal or microorganisms is handled outside the BSC or another containment device. Eye protection and face protection are disposed of with other contaminated facility waste or decontaminated after use. • Personnel who wear contact lenses should also wear eye protection when entering areas with potentially high concentrations or airborne particulates. • Persons having contact with NHPs assess the risk of mucous membrane exposure and wear protective equipment (e.g., face 	<ul style="list-style-type: none"> • Personnel within the animal facility wear protective clothing, such as uniforms or scrubs. • Disposable PPE such as non-woven, olefin cover-all suits, or wrap-around or solid-front gowns are worn over this clothing before entering areas where infectious materials and/or animals are housed or manipulated. Front-button, laboratory coats are unsuitable. • Reusable clothing is appropriately contained and decontaminated before being laundered. Animal facility and protective clothing is never taken home. • Disposable PPE is removed when leaving the areas where infectious materials and/or animals are housed or manipulated. Scrubs and uniforms are removed before leaving the animal facility. • Disposable PPE and other contaminated waste are appropriately contained and decontaminated prior to disposal. • All personnel entering areas where infectious materials and/or animals are housed or manipulated wear appropriate head covering, eye, face, and respiratory protection. • Head covering, eye protection, and face protection are disposed of with other contaminated animal facility waste or decontaminated after use. • Personnel who wear contact lenses in laboratories must also wear eye protection. • Gloves are worn to 	<ul style="list-style-type: none"> • Not permitted at ASU. • Please refer to the CDC/NIH document, "Biosafety in Microbiological and Biomedical Laboratories" for PPE requirements.

	<p>shield, surgical mask, goggles), as appropriate.</p> <ul style="list-style-type: none"> • Additional PPE is considered for persons working with large animals. • Gloves are worn to protect hands from exposure to hazardous materials and when handling animals. • Based on the pathogen and work performed, respiratory protection may be considered for staff enrolled in a properly constituted respiratory protection program. • When research animals are present, a risk assessment considers appropriate eye, face, and respiratory protection, as well as potential animal allergens. 	<p>protect hands from exposure to hazardous materials and when handling animals.</p> <ul style="list-style-type: none"> • Procedures may require wearing two pairs of gloves (i.e., double glove). Change outer gloves when contaminated, glove integrity is compromised, or when otherwise necessary. • Additional PPE is considered for persons working with large animals. • To prevent cross-contamination, boots, shoe covers, or other protective footwear are used where indicated and disposed of or decontaminated after use. 	
--	---	--	--

* Safety is improved when PPE is used in combination with physical containment devices or equipment, such as biological safety cabinets, or BSCs. Additional PPE may be required as determined by risk assessment.

It is the responsibility of institutional management to provide facilities, staff, and established practices that reasonably ensure appropriate levels of environmental quality, safety, security, and care for the laboratory animal. There are unique hazards associated with infected animals that must be understood by personnel with animal contact. Animal activity may create aerosols, and bites and scratches can occur.

IX. Arthropod Containment Levels

Similar to the BSL and ABSL, there are four arthropod Containment Levels 1–4 (ACL-1 to -4). These containment levels are recommended by the American Society of Tropical Medicine and Hygiene or ASTMH and the American Committee of Medical Entomology or ACME for work with uninfected arthropods, those carrying infectious agents, and for work with transgenic vector arthropods in laboratory settings. The [Arthropod Containment Guidelines \(ACG\)](#) recommend biosafety measures for arthropods of public health importance. Field research sites that include work with arthropods can be defined by the type of activities, duration, risks to researchers and other factors but are not the focus of the ACG document.

The four Arthropod Containment Levels (ACL 1–4) add increasingly stringent measures and are similar to Biosafety Levels. Like the BMBL, each level has four components, including: standard practices; special practices; equipment (primary barriers); and facilities (secondary barriers).

The four ACL levels provide increasing levels of protection to personnel and to the environment and are recommended as minimal standards for activities involving infected laboratory arthropods. In addition, the ACG document addresses how to prevent escapes when working with arthropods. The ASU IBC will assign the correct ACL level for each research project.

The following bullets provide a brief summary of the four arthropod containment levels:

- **ACL-1** is required for work with uninfected arthropod vectors or those infected with a nonpathogenic, including (1) arthropods that are already present in the local geographic region regardless of whether there is active vector-borne disease transmission in the locale and (2) exotic arthropods that on escape would be nonviable or become only temporarily established in areas not having active vector-borne disease transmission.
- **ACL-2** is required for work with exotic and indigenous arthropods infected with BSL-2 agents associated with animal and/or human disease, or that are reasonably suspected of being infected with such agents (e.g., diagnostic samples).
- **ACL-3** is required for work with potential or known vectors that are or are likely to be infected with BSL-3 agents associated with human disease. Arthropods that are infected or potentially infected with BSL-3 pathogens may pose an additional hazard if the insectary is located in an area where the species is indigenous, or if alternative suitable vectors are present, as an escaped arthropod may introduce the pathogen into the local population. In the United States, the Select Agent Rule (<http://www.selectagents.gov>) restricts access to certain pathogens of human or veterinary importance, all classified at BSL-3 or BSL-4. Many of these Select Agents are naturally maintained by arthropods. All possession and use of these restricted agents must comply with the biosecurity requirements promulgated by the United States Title 42 CFR Part 72. Violations are criminal offenses.
- **ACL-4** is required most dangerous pathogen-infected arthropods. All of the Standard Practices of ACL-3 should be in place, with the additional safety precautions listed in the ACG and as specified by the IBC. BSL-4 agents are associated with a high risk of infection from aerosol exposure and cause life-threatening disease. Certain other pathogens such as those listed as “restricted animal pathogens” may also necessitate BSL-4 containment if used in vectors. If work with vectors must be performed in a BSL-4 facility, then BSL-4 requirements must be strictly followed. As described below, vectors must be safely contained at all times possibly by use of specially designed apparatus that is tested and approved before use.

Personal protective equipment varies depending upon the arthropod containment level. Please refer to the following table for specific requirements for each of the four biological safety levels.

Table 4. Arthropod Containment Levels - Personal Protective Equipment (PPE) Requirements*

ACL-1	ACL-2	ACL-3	ACL-4
<ul style="list-style-type: none"> • Protective white laboratory coats, gowns, or uniforms should be worn at all times in the insectary when handling blood and vertebrate animals. • Personal protective equipment is worn as appropriate, for example, respirators for arthropod-associated allergies, particle masks, and head covers, but local risk assessment and institutional policy may provide exceptions. • Personnel who wear contact lenses should also wear eye protection when entering areas with potentially high concentrations or airborne particulates. • Latex or nitrile gloves should be used when handling host animals or blood used to feed the arthropods, but local risk assessment and institutional policy may provide exceptions. 	<ul style="list-style-type: none"> • White laboratory coats, gowns, and/or uniforms are worn at all times in the insectary when handling vertebrate animals and infected materials. Universal blood precautions (BMBL6) are recommended when blood is manipulated. • Clothing should minimize the area of exposed skin (e.g., skirts, shorts, open-toed shoes, sandals, and tee shirts are inadvisable), since this can increase the risk of attracting and being bitten by a loose arthropod. • Appropriate face/eye and respiratory protection is worn by all personnel entering the insectary, if recommended by the local risk assessment. • Personnel who wear contact lenses must also wear eye protection when entering the insectary. • Gloves (latex or nitrile) are worn when handling potentially infected arthropods, blood, and associated equipment and when contact with potentially infectious material is unavoidable. Local risk assessment may provide for exceptions, for example, the need for dexterity or tactile control (e.g., during the inoculation of suckling mice). • Other equipment may be required as determined by the local risk assessment. Homogenization of infected arthropods, for example, may require an appropriate respiratory protective device if the procedure is not performed within a biosafety cabinet or glove box. 	<ul style="list-style-type: none"> • Changing out of street clothes into scrubs, to be worn under PPE, is highly recommended. White laboratory coats, gowns, or jumpsuits should be worn at all times by all personnel entering the insectary. Wraparound or solid-front gowns are typically worn over this clothing. Front button laboratory coats alone are unsuitable. The gowns are removed and left in the insectary. Before leaving the insectary, scrub suits are removed and appropriately contained and decontaminated before laundering or disposal. • Personal clothing as per ACL-2. • Appropriate eye, face and respiratory protection as per ACL-2. Personnel who wear contact lenses must also wear eye protection when entering the insectary. • Gloves (latex or nitrile) are worn when handling infected arthropods or host animals and associated equipment. Gloves are removed aseptically and are changed frequently. Under specific circumstances, and as allowed by institutional review of practices and procedures specific to the site and task, gloves may not be required, for example, in restraining suckling mice for inoculation (tactile cues and dexterity are required for safe execution of this procedure, as well as for humane purposes). • Boot, shoe covers, or other protective footwear and disinfectant foot baths (with appropriate anti-arthropod measures) are available and used where indicated. Footwear dedicated for use in the ACL-3 facility is highly recommended. 	<ul style="list-style-type: none"> • Not permitted at ASU. • Please refer to the <i>Arthropod Containment Guidelines</i>, Version 3.2 for requirements.

* It is the responsibility of institutional management to provide facilities, staff and established practices that reasonably ensure appropriate levels of environmental quality, safety, security and care for arthropods. Arthropods present unique containment challenges not encountered with microbial pathogens. Other challenges include that arthropod containment has not been covered specifically in BMBL or the NIH Guidelines.

X. Training for working safely with biohazards

The principal investigator and/or laboratory supervisor is responsible for providing or arranging for site-specific training of all personnel. In addition, each employee must attend biosafety, lab safety, hazardous waste management and chemical safety training. Contact ASU EHS or the Biological Safety Officer for more information on training. All training must be documented annually, and records maintained by the principal investigator and/or laboratory supervisor. Please refer to the ASU [Laboratory-Specific Training Checklist](#) for more information.

XI. Biohazardous research project registration

Each principal investigator is responsible for the preparation of the Institutional Biosafety Committee disclosure for all research involving potentially biohazards, including the assignment of the required Biological Safety Level (BSL) to the proposed biological research. The Institutional Biosafety Committee, in conjunction with the Biological Safety Officer, will review all submitted registration documents; confirm, where applicable, that exempt status is appropriate for certain recombinant or synthetic nucleic acid work; and consider approval for those registration documents that are complete and that provide for safe handling of potentially biohazards under the appropriate biosafety level. Registration information can be found on the Institutional Biosafety Committee [website](#).

A. Select agents and toxins

Select agents are certain microorganisms and toxins specifically identified in federal regulations. Select agents also include nucleic acids that encode for any select agent or toxin. Select agents and toxins have been determined to have the potential to pose a severe threat to both human and animal health, to plant health, or to animal and plant products. An attenuated strain of a select agent or an inactive form of a select toxin may be excluded from the requirements of the Select Agent Regulations. Certain select agent toxins are not regulated as select toxins if the amount under the control of a principal investigator, treating physician or veterinarian, or commercial manufacturer or distributor does not exceed, at any time, the amounts indicated in the following table.

Select agent toxins	CAS #	Amount
Abrin	1393-62-0	1,000 mg
Botulinum neurotoxins	93384-43-1	1 mg
Diacetoxyscirpenol (DAS)	2270-40-8	10,000 mg
Ricin	96638-28-7	1,000 mg
Saxitoxin	35523-89-8	500 mg
Short, paralytic alpha conotoxins	76862-65-2 / 156467-85-5	100 mg
Staphylococcal enterotoxins (Subtypes A, B, C, D, and E)	11100-45-1	100 mg
T-2 toxin	21259-20-1	10,000 mg
Tetrodotoxin	4368-28-9	500 mg

The ASU Biosafety Manual, when used in combination with the **Laboratory-Specific Biosafety Manual**, is designed to meet the federal requirements of the Department of Health and Human Services (HHS) Standard, 42 CFR § 73, "[Possession, Use, and Transfer of Select Agents and Toxins; Final Rule](#)" and the Department of Agriculture (USDA) Standards, 7 CFR § 331 and 9 CFR § 121, "[Agricultural Bioterrorism Protection Act of 2002; Possession, Use, and Transfer of Biological Agents and Toxins; Final Rule](#)."

B. Toxins of biological origin

Any biological toxin with a median lethal dose, or LD₅₀, of less than 100 micrograms per kilogram body weight in vertebrates, must be approved by the ASU [Institutional Biosafety Committee](#) prior to beginning research. Research with recombinant or synthetic nucleic acid molecules containing genes for the biosynthesis of toxin molecules lethal for vertebrates at an LD₅₀ of less than 100 nanograms per kilogram body weight requires pre-approval from the National Institutes of Health's Office of Biotechnology Activities.

Examples of biological toxins with an LD₅₀ of less than 100 nanograms per kilogram include the botulinum toxins, tetanus toxin, diphtheria toxin, and *Shigella dysenteriae* neurotoxin.

C. Human blood and tissue

In any laboratory where work involves the use of and/or exposure to human blood, body fluids, or unfixed human tissue, including human cell cultures, there is the danger of exposure to bloodborne pathogens (disease-causing microorganisms) that may be found in such material. Research with material of human origin (e.g., blood, tissue, organs, cell lines) is regulated by the Occupational Safety and Health Administration. Work with this material must follow the ASU [Bloodborne Pathogens Exposure Control Plan](#). In addition, when human blood or tissue donors are involved, the principal investigator must contact ORIA to determine whether a human subject Institutional Review Board application is required.

D. Recombinant and synthetic nucleic acid molecules

The use of recombinant and synthetic nucleic acid molecules is regulated by the NIH, as outlined in the NIH Guidelines. At ASU this research must be reviewed by the Institutional Biosafety Committee prior to initiation of the work. Guidelines include registration of the recombinant or synthetic nucleic acid molecules, understanding the classification of the use of work, and safe work practices/proper disposal of material (including whole animals) containing recombinant or synthetic nucleic acid molecules. The use of more than 10 liters of organisms containing recombinant or synthetic nucleic acid requires special practices and IBC approval.

E. Environmental samples

Environmental samples, such as water, air, soil or plants, may contain pathogens (e.g., bacteria, viruses, spores) that could present a health hazard to people, animals, or the environment. Using appropriate personal protective equipment when collecting environmental samples will reduce exposure to potential pathogens and minimize transfer of pathogens in the environment. Use care when handling environmental samples, especially if the sample will be enhanced in the laboratory by culturing or other growing mechanisms, including greenhouses. Techniques used to enhance and/or culture environmental samples should be conducted at BSL-2 or higher levels in an appropriate containment device, such as a biological safety cabinet. If the environmental sample is sterilized prior to experimentation, then the sample may be manipulated in a BSL-1 rated laboratory. All other environmental samples must be registered with the ASU [Institutional Biosafety Committee](#). Environmental samples are also subject to USDA APHIS and CDC transit and import permit regulations and additional state permits. Researchers should contact ASU Biosafety for assistance in determining whether permits for obtaining environmental samples are required.

XII. Controlled substances

The Controlled Substances Act (Title II of the [Comprehensive Drug Abuse Prevention and Control Act of 1970](#)) places all substances regulated by federal law into one of five schedules or categories based on the medicinal value and the potential for abuse. The Drug Enforcement Administration (DEA), part of the U.S. Department of Justice, has control and enforcement authority for controlled substances. Many drugs used for medical treatment, anesthesia, analgesia, or euthanasia are considered controlled substances. In order to legally purchase, store, use, dispense, and dispose of these drugs a DEA license is required. Table 5 lists the five schedules of controlled substances.

	Potential for abuse	Medical use	Examples
Schedule I	High	None	Heroin Hydromorphanol Marijuana Lysergic Acid Diethylamide
Schedule II	High	With restrictions	Fentanyl Methadone Oxymorphone Pentobarbital
Schedule III	Less than I or II	Currently accepted medical use	Euthanasia solutions Nalorphine Buprenorphine Ketamine Hydrochloride
Schedule IV	Low	Currently accepted medical use	Chloral Hydrate Phenobarbital Butorphanol
Schedule V	Lower than IV	Currently accepted medical use	Codeine

Investigators who use controlled substances in their laboratory must obtain a Researcher DEA license. As an ASU employee, the license is free. Information on how to apply for a Researcher DEA license as well as detailed instructions on how to complete the online application can be found within the ORIA website under the [Animals, substances, and supplies](#) section.

The initial application is submitted on the DEA registration [website](#). Once the online application process has been completed, additional documents that need to be completed will be forwarded to the principal investigator (PI) by the DEA. Once the DEA has completed the application process, the DEA license will be mailed to the PI. The entire process takes approximately four to six weeks. The license must be renewed annually.

Once the PI secures a DEA license, they may procure controlled substances independently. In order to order or obtain Schedule I or Schedule II drugs, a DEA 222 [form](#) is required.

All persons possessing controlled drugs must maintain specific records for a minimum period of two years per DEA requirements. Inventories and records of controlled substances listed in Schedules I and II must be maintained separately from all other records maintained by the registrant. Information that must be on file and available for review includes:

1. **Inventory.** After an initial inventory is taken, a new inventory of all controlled substances on hand should be taken at least once every two years. Each inventory must contain the following information:
 - Date and time the inventory was taken.
 - A list of all unopened bottles by drug name, including the drug name, the number of bottles, the drug concentration or unit size (e.g., 100mg/ml or 50 mg tablets), and the amount of drug in the bottle (e.g., ml or tablets). For example: ketamine, 2 bottles, 100 mg/ml, 10 ml per bottle.

- A list of all opened bottles and, for each bottle, the drug name, the drug concentration or unit size (e.g., 100 mg/ml or 50 mg tablets), and the amount of drug in the bottle before opening, (e.g., ml/bottle or tablets/bottle) and the remaining units. For example: ketamine, 100 mg/ml, originally 10 ml per bottle, 4.5 ml remaining.
2. **Transfer form or Controlled Drug Inventory form.** If you obtain controlled substances through a different DEA-licensee, or transfer drugs from your inventory (e.g., for reverse distribution of expired drugs), you must maintain a copy of the Transfer Form for a period of two years.
 3. **Controlled Substance Administration Record, or CSAR.** When a controlled substance is administered, its usage must be documented. CSAR forms can be provided to PIs to use, or the PI can generate their own tracking form. However, it is essential that all needed information is included. This includes license holder's name and DEA number, name of drug, drug schedule number, concentration, starting amount, bottle ID, and bottle lot number. For each use from the bottle, the following needs to be recorded: date, name of user, amount used, amount remaining, and the initials of the person entering the information.

As per DEA regulations, expired or unused controlled substances must be disposed of via reverse distribution.

XIII. Animal research project registration

A. Vertebrate Animals

Research involving live vertebrate animals must be registered and approved by the ASU [Institutional Animal Care and Use Committee](#), or IACUC.

B. Arthropod Research Project Registration

Arthropod research projects that do not fall under the purview of the IBC or IACUC committees must still be registered with ASU EHS. EHS will conduct a risk assessment to determine the appropriate standard and special practices, equipment, and facilities as outlined in the Arthropod Containment Guidelines published by the American Committee of Medical Entomology, a subcommittee of the American Society of Tropical Medicine and Hygiene. Contact biosafety@asu.edu for assistance.

XIV. Field research project registration

Field research projects must be registered with the corresponding institutional committees, IBC, IACUC or IRB depending on the nature of the research. In addition, trips associated with field research projects may require registration in the ASU travel system. Please refer to ASU Travel Guidance webpage. Students participating in field research in international locations must register with ASU Global Education.

The ASU Field Research Safety Manual provides the requirements, policies, guidelines, and resources for ASU personnel to conduct field research safely and successfully. The manual is designed to enable ASU personnel to minimize risks associated with conducting field research in local, regional, national, or international [locations](#).

For assistance with field research projects, contact ASU EHS at biosafety@asu.edu.

XV. Biohazardous waste

According to the State of Arizona, biohazardous waste is defined as:

- Any solid waste which is generated in the diagnosis, treatment, or immunization of a human being or animal or in any research relating to that diagnosis, treatment, or immunization, or in the production or testing of biological materials.
- Animal carcasses, body parts, and bedding of animals that have been infected with agents that produce, or may produce, human infection.
- Discarded cultures and stocks generated in the diagnosis, treatment, or immunization of a human being or animal or in any research relating to that diagnosis, treatment, or immunization, or in the production or testing of biological.
- Discarded products and materials containing blood or blood components.
- Discarded organs and body parts removed during surgery.
- Discarded sharps used in animal or human patient care, medical research, or clinical laboratories. Examples of sharps include hypodermic needles, syringes, pipettes, pipette tips, scalpel blades, blood vials, needles attached to tubing, broken and unbroken glassware, slides, and coverslips.

The National Institutes of Health's "Guidelines for Research Involving Recombinant or Synthetic Nucleic Acid Molecules" (NIH Guidelines) requires ASU to manage discarded preparations made from genetically altered living organisms and their products as biohazardous waste. For example, recombinant or synthetic nucleic acid waste materials used in research laboratories is considered biohazardous waste. All waste containing recombinant or synthetic nucleic acid molecules must be inactivated prior to disposal.

XVI. Animal waste

Wastes unique to the animal facility include animal bedding and animal carcasses. These are generated along with the sharps and other biologically contaminated equipment that typically need to be discarded in all laboratories. All animal waste must be treated prior to disposal unless an alternate disposal method has been pre-approved by EHS. In most instances, the procedures for animal waste and/or carcasses are summarized below.

- Sharps from an animal facility are disposed of in sharps containers and disposed of according to ABSL-specific procedures. After these ABSL-specific procedures, sharps containers are placed in the red barrels for biological waste when in an animal facility. All other biologically contaminated material is also placed in the red barrels. When the red barrel is full, it is the responsibility of the laboratory staff to contact EHS for pick-up. Contact DACT with questions regarding sharps disposal in an animal facility.
- Typically, animal carcasses are bagged, sealed, and stored in refrigerators/freezers located in each animal facility until pick up by EHS for incineration. Specific instructions for disposal of animals can depend upon the designated ABSL level. Contact DACT with questions regarding carcass disposal.
- Soiled animal bedding is disposed of according to ABSL-specific procedures but is generally collected into EHS red barrels for disposal. Contact DACT with questions regarding animal bedding disposal.

XVII. Biohazardous waste handling

Wastes associated with biological research materials must be disposed of in special ways. Examples of potentially hazardous items include:

- All sharps (e.g., glass implements, needles, syringes, blades, coming from facilities using infectious materials).
- Agents of any biosafety level containing recombinant or synthetic nucleic acid molecules.
- Animal bedding and animal carcasses.
- Archaeological samples (e.g., bones, clothing fragments, containers).
- Biologically cultured stocks and plates.
- Environmental samples (e.g., soil, water, plants, sewer).
- Genetically modified or transgenic plants and animals.
- Human or animal blood, tissues, organs and cell lines.
- Any other regulated biohazardous material.

In order for EHS to remove biological waste, the following procedures must be followed:

- Biological wastes derived from human and animal sources (e.g., blood, body fluids, tissues, tumors, human cell lines) are hazardous biological wastes and should be placed in a red or orange biohazard bag. Autoclave the bag under appropriate time and temperature and place it in a red drum for removal by hazardous waste personnel.
- Bacteria, viruses, or other microorganisms that are known human pathogens should also be put into a red biohazard bag, autoclaved, and placed in a red drum for removal by hazardous waste personnel.
- BSL-1 materials containing recombinant or synthetic nucleic acid must be autoclaved or it must be destroyed with bleach (approval must be received from EHS prior to drain disposal).
- Non-human biological wastes are handled by the same methods as human biological wastes: placed in autoclave bags, autoclaved, and put into red drums for removal by hazardous waste personnel.
- Sharps and sharp objects such as glass, syringes, disposable pipettes, and pipette tips that may be contaminated with biohazards (human or non-human) must be placed in a rigid, leak-proof, puncture-resistant container. The container is autoclaved and then placed in a red drum for removal by hazardous waste personnel. Note: Needles and other medical sharps must be collected in sharps containers.
- Other wastes, including waste from genetically modified plants and animals, as well as environmental and archaeological samples, are considered biohazardous waste. These wastes should either be chemically inactivated or autoclaved, and placed in a red biohazard bag. Autoclave the bag using appropriate time and temperature and place it in a biohazard drum for removal by hazardous waste personnel.

When a “red-bag,” “yellow drum” or liquid hazardous waste is ready for removal, **contact EHS** to arrange a pick-up, or submit a [hazardous waste pick-up request](#). If you need any other assistance or have questions, please feel free to contact Environmental Health and Safety at 480-965-1823.

XVIII. Laboratory procedures and equipment

A. Exposure control

The term “containment” is used in describing safe methods for managing biohazardous and select agents and toxins in the laboratory environment where they are being handled or maintained. The purpose of containment is to reduce or eliminate exposure of laboratory workers, other people, and the outside environment to potentially hazardous agents. The three elements of containment include laboratory practices and techniques, safety equipment, and facility design. The risk assessment of the work to be done with a specific agent will determine the appropriate combination of these elements. Each principal investigator is required to complete a “Certificate of Hazard Assessment: Personal Protective Equipment Form for each biological agent and toxin stored in his or her laboratory. Copies of the Health Hazard Assessments must be included in the principal investigator’s Laboratory-Specific Biosafety Manual.

1. Laboratory practice and technique

The most important element of containment is strict adherence to standard microbiological practices and techniques. Persons working with infectious agents or infected materials must be aware of potential hazards and must be trained and proficient in the practices and techniques required for handling such material safely. The principal investigator of each laboratory is responsible for providing or arranging the appropriate training of personnel and for verifying each person’s competence. In addition, each principal investigator must develop a Laboratory-Specific Biosafety Manual to address the use, handling, and disposal of biohazardous material (including select agents and toxins) in the laboratory.

The Laboratory-Specific Biosafety Manual must identify specific hazards that will or may be encountered and consider procedures needed to minimize or eliminate risks. Personnel should be advised of special hazards and are expected to follow the required practices and procedures.

2. Safety equipment | Primary barriers

Safety equipment includes biological safety cabinets, enclosed biohazardous containers, and other engineering controls designed to eliminate or minimize exposures to biohazards and toxins. The biological safety cabinet is the principal device used to provide containment of infectious splashes or aerosols generated by many microbiological procedures. More information on biological safety cabinet may be found in the “biological safety cabinet” section of this manual.

Primary safety barriers may also include personal protection equipment, or PPE, such as gloves, lab coats, safety glasses or goggles, face shields and respirators. Personal protective equipment is often used in combination with biological safety cabinet and other containment devices. In some situations, in which it is impractical to work in a biological safety cabinet, personal protective equipment may form the primary barrier between the worker and the infectious materials.

ASU policy requires the use of gloves, lab coat and eye protection at all times when handling biohazards.

3. Facility design | Secondary barriers

The design of a facility is important in providing a barrier to protect those working inside and outside the laboratory and to protect people, plants, or animals in the

community from biohazards and toxins which may be accidentally released from the laboratory. Facilities must be commensurate with the laboratory's function and the recommended biosafety level for the agent being manipulated.

The secondary barriers required will depend on the risk of transmission of specific agents. For example, in working with agents at Biosafety Level 2 (BSL-2), the exposure risks involve direct contact with the agents or inadvertent contact through contaminated work environments. Recommended secondary barriers in these laboratories include separation of the laboratory work area from public access, hand washing facilities, and availability of a decontamination facility such as an autoclave.

When the risk of infection by exposure to an infectious aerosol is present, higher levels of primary containment and multiple secondary barriers may become necessary to prevent infectious agents from escaping into the environment. Such design features include specialized ventilation systems to ensure directional airflow, HEPA filtration to remove agents from exhaust air, controlled access zones, airlocks as laboratory entrances, or separate modules to isolate the laboratory.

B. Biological safety cabinets, or BSC

Biological safety cabinets are classified as Class I, Class II or Class III cabinets. When properly maintained and operated, they effectively contain and capture microbial contaminants and infectious agents using HEPA (High Efficiency Particulate Air) filters (See Figure 1. Source: Biosafety in Microbiological and Biomedical Laboratories 6th edition). Biosafety cabinets should not be confused with clean benches which only protect the material being worked with and are not suitable for work with infectious or toxic material. (Although clean benches, like biological safety cabinets, have HEPA-filtered air, in clean benches the air flows over the experimental material toward the user rather than being drawn away.) Biological safety cabinets should also not be confused with conventional fume hoods that do not filter microorganisms.

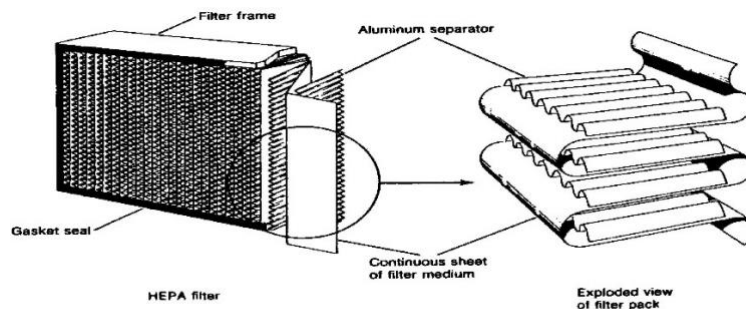
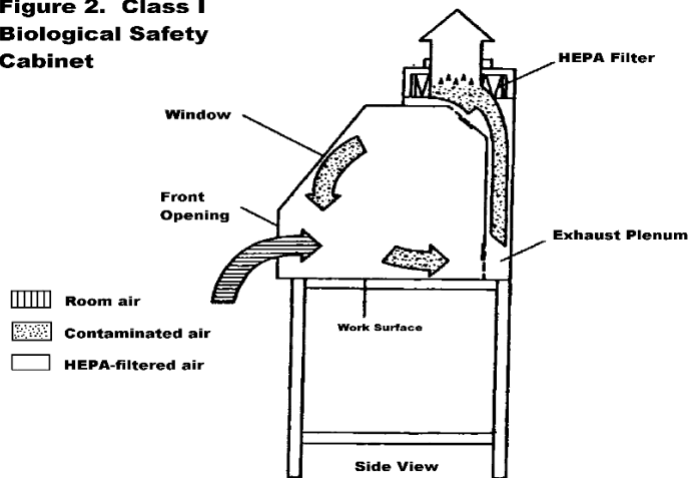

Figure 1. Diagram of HEPA filter. These filters are typically constructed of continuous sheets of paper-thin filter medium, pleated to increase surface area, divided by aluminum separators, and affixed to a frame.

Class I biological safety cabinets provide personnel and environmental protection, but not product protection (See Figure 2. Source: Biosafety in Microbiological and Biomedical Laboratories 5th Edition).

Figure 2. Class I Biological Safety Cabinet



Class II biological safety cabinets are the most commonly used biological safety cabinet at ASU for biohazards. These cabinets provide personnel, environmental, and product protection (See Figure 3. Source: Biosafety in Microbiological and Biomedical Laboratories 5th Edition). Only those which are hard ducted to the outside and provide a face velocity of 80 to 125 feet per minute should be used when working with volatile chemicals. Additionally, cabinets are not designed to prevent ignition of volatile flammable chemicals, such as ethanol and isopropanol.

Figure 3. Class II, Type A Biological Safety Cabinet

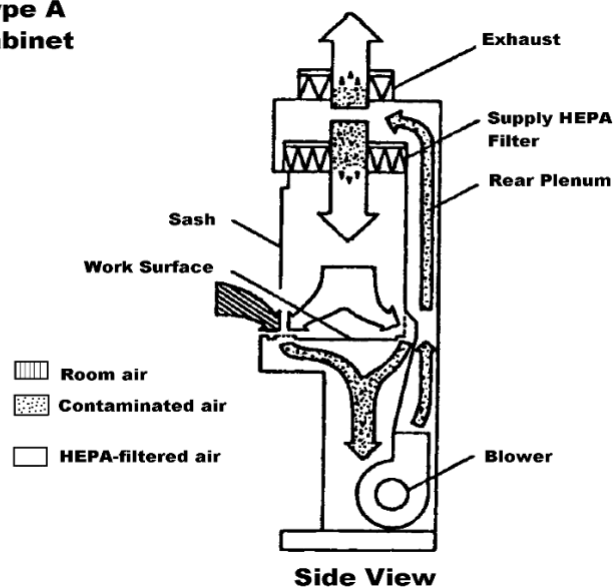

C. Steps for working in a biological safety cabinet

1. Turn on the fluorescent lamp.
2. Make sure the biological safety cabinet is certified.
3. Inspect the air intake grilles for obstructions and foreign material and remove if necessary.
4. Turn the cabinet on for at least 10 minutes prior to use if the cabinet is not left running.

- Ensure the air flow indicator confirms inward air flow.
5. Don appropriate PPE. Put on laboratory coat. Put on safety glasses and a pair (or two pairs) of high-quality nitrile gloves.
 6. Disinfect work surface and surfaces of all materials to be placed inside the BSC with an appropriate EPA registered disinfectant.
 7. Place items into the BSC, at least 6 inches from the front grill and approximately two to four inches from the rear grill, without unnecessary disruption of the airflow.
 8. Items used for surface decontamination and cleanup of a small spill should be included inside the BSC. Ensure there are biohazard waste containers directly outside of the BSC, but not attached to the unit as it can disrupt airflow.
 9. Adjust the working height of the stool so that the worker's face is above the front opening.
 10. Employ good microbiological practices, work with materials from the clean to the dirty side.
 11. Minimize the movement (e.g., sweeping) of arms and reduce the frequency of placing hands/arms into the BSC and taking them out.
 12. Wipe the bottom and side surfaces with disinfectant when work is completed.

Note: Be very careful when using small pieces of materials such as paper tissues in the hood. These can be blown into the hood and disrupt the motor operations. Ultraviolet lamps are not recommended for use in BSCs. For more information, please contact EHS.

D. Certification of the biological safety cabinet

Biological safety cabinets provide a partial containment system for the safe handling of pathogenic microorganisms, environmental samples, and other biohazardous materials. To ensure safety, biological safety cabinets must be used correctly with good microbiological techniques and be in proper mechanical working order. Cabinets must be certified for performance upon installation using National Sanitation Foundation, or NSF, Standard #49. Certification is a series of performance tests on the biological safety cabinet to confirm that it will provide the user and experimental material the protection for which it is designed. The airflow, filters, and cabinet integrity are checked to ensure that the cabinet meets minimum performance standards. A list of vendors who provide certification is maintained by EHS Biosafety.

Biological safety cabinets intended for research with biohazards must be certified:

- After they are received and installed (before use with infectious materials).
- After filter changes.
- After being moved (even a few feet).
- After a mechanical failure.
- Annually.

Biological safety cabinet decontamination (using formaldehyde gas, chloride dioxide gas, or other approved method) may be provided (e.g., by an outside vendor) and needs to be done:

- Before any maintenance work requiring disassembly of the air plenum, including filter replacement.
- Before moving the cabinet to a new laboratory.
- Before discarding or salvaging.
- Prior to cabinet recertification.

The production of formaldehyde gas is a health concern. Many biological safety cabinets

at ASU are not ducted to the outside; therefore, consideration of a temporary “cease work” order may be implemented, and extreme caution must be used when having the procedure performed.

E. Decontamination

Decontamination is a process or treatment that renders an instrument or environmental surface safe to handle. A decontamination procedure can be as simple as clean-up with detergent and water or as thorough as sterilization. Sterilization and disinfection are two ways to address microbial contamination.

- Antisepsis is the application of a liquid antimicrobial to skin or other living tissue to inhibit or destroy microorganisms. Examples include hand washing with germicidal solutions or swabbing skin with alcohol before an injection.
- Disinfection is a chemical or physical treatment that destroys the most resistant vegetative microbes or viruses, but not the spores, in or on inanimate surfaces. Effectiveness is influenced by several factors, including the type and number of organisms, amount of organic matter, the object being disinfected, the disinfectant being used, concentration, temperature, and exposure time.
- Sterilization is the use of physical or chemical processes to destroy all viable forms of microbial life, such as bacterial spores.

1. Sterilization, disinfection, and antisepsis are all forms of decontamination.

When to decontaminate

In most ASU laboratories, it is recommended that decontamination be accomplished by steam heat sterilization in an autoclave or by surface application of or placement in a chemical disinfectant solution, such as 1:10 bleach solution or an [EPA-registered disinfectant](#) and applied per manufacturer instructions.

All material and equipment contaminated with or containing potentially biohazards should be decontaminated:

- At least daily.
- Before being washed, stored, or discarded.
- In the event of spills of biohazards.
- Upon completion of procedures involving the use of biohazardous material.

2. Autoclave use

Autoclaving (saturated steam under pressure of approximately 15 pounds per square inch (psi) to achieve a chamber temperature of at least 250°F for a designated time) is the preferred and most convenient method to rapidly destroy all forms of microbial life. However, to do this, the autoclave process must reach proper temperature, pressure, and time, and prevent the entrapment of air in the bag or container of treated material.

- Material to be sterilized must come into contact with steam.
- Bags or containers should be left open during autoclaving or water (~200 ml) should be added to sealed bags to generate steam.
- Heat indicator tape should be used outside the bag or container with each autoclave load to indicate that sterilization has been completed.
- Autoclave sterility monitoring should be conducted on a regular basis using

biological indicators (such as *G. stearothermophilus* spore strips) placed among treated materials and at locations throughout the autoclave. The spores, which are more resistant to heat than most other biological materials, provide validation of general microbial destruction when they are effectively inactivated by autoclave operation (typically 250 F for 30 minutes).

- Note that the type and frequency of sterility monitoring varies and is based on usage, cycle type, and autoclave type. Contact EHS [Biosafety/Biosecurity](#) for more information.

The [ASU Autoclave Safety Manual](#) provides autoclave information, guidelines, policies, and procedures enabling staff using autoclaves to work safely and eliminate, or reduce, the potential for exposure to hazards or potentially infectious materials. All personnel who use autoclaves at ASU must have successfully completed the ASU Biosafety and Bloodborne Pathogens Training, the [ASU Autoclave Training](#) and received in- person training from their supervisor regarding the safe use and operation of autoclaves.

3. **Chemical disinfectant use**

The most practical use of chemical disinfectants is for surface decontamination and, when used in sufficient concentration, as a decontaminant for liquid wastes prior to final disposal.

4. **Liquid decontamination**

- Add liquid chlorine bleach to provide a final 1:10 (made fresh weekly);
- Let stand at least 20 minutes; and
- Discard the solution appropriately. Note: No waste down the drain unless approval has been obtained from EHS.

5. **Surface decontamination**

- Wipe with 1:10 dilution of chlorine bleach; or
- Wipe with iodophor disinfectant (per label concentration); or
- Wipe with another EPA registered disinfectant following manufacturer guidelines.

See [Appendix C](#) for additional information on disinfectants.

F. Decontamination in animal facilities

In ASU animal facilities, decontamination is accomplished by use of the provided disinfectants applied to surfaces and equipment; by chemical sterilants; by steam heat sterilization in an autoclave (particularly for surgical equipment and for bedding, animal feed, and other materials used in the barrier animal facility); by gas sterilization; or by use of the cage-washing machine. All animal users should be familiar with the safe and proper use of all chemical decontamination materials and equipment that they need to use as part of their animal lab responsibilities.

XIX. Animal hazards and exposures

Good housekeeping practices and sanitation are essential to reducing the risk of physical hazard injuries. It is important to keep work surfaces clean and clear of obstructions, waste, and other materials. All boxes, hoses, or bags of bedding material should be routinely removed from the work area. Mop floors and clean work surfaces with the appropriate cleaning and disinfectant solutions. Keep in mind that poor housekeeping is unprofessional and will increase the risk of accidents and injuries.

A. Bites and scratches

The risk of animal bites and scratches is associated with handling of animals and is best avoided by proper handling techniques and wearing appropriate personal protective equipment. Knowledge of animal behavior and how animals respond to their immediate physical environment is important in reducing risk of injury to the individual and the animal.

Animals respond to sights, sounds and smells as people do, but they also may hear, smell and react to things that people do not detect. For example, if an animal hears a high-pitched sound, it may become frightened and react defensively. Many animals have a flight zone, and, if approached by another animal or the handler, the affected animal may try to escape. Unsuccessful escape may cause the animal to act aggressively. Of course, inappropriate handling of an animal can cause discomfort, pain, and distress and provoke an animal to bite or scratch.

Animal bites and scratches that cause minor skin damage are sometimes disregarded by animal workers who are unfamiliar with the number of diseases that can be spread by such injuries. Even minor bites and/or scratches can result in infections and illnesses if they are not properly treated. Scrapes and injuries from **contaminated equipment** associated with animal care and housing, such as cages, can be as great a risk as direct animal contact and should be addressed similarly.

Most animals used in research are bred specifically for that purpose and do not have the potential for transmitting the kinds of pathogenic organisms that those in the wild do; however, there are some illnesses and infections that can be passed from animals to people (i.e., zoonoses), and these are discussed in more detail later in this document.

With research animals, biological hazards are of most concern when the animals are naturally infected (e.g., macaques may have Simian Herpes B virus) or if animals are infected with a bacteria, virus or human cells (e.g., tumorigenic cell lines) as part of the experimental work. Under these conditions and when doing field research with wild species, it is of critical importance that appropriate PPE and other appropriate protective measures be used to prevent infection.

The most important step to prevent infection following any bite, scratch (or puncture from sharps exposure) is to immediately and thoroughly wash the injury with soap and water. Inform a supervisor and submit an [incident report](#). Contact ASU Employee Health for medical consultation or treatment. Incidents and injuries involving non-human primates (NHPs) must follow the NHP Bite/Scratch standard operating procedures (SOP). In addition, everyone working with NHPs must attend the mandatory annual B-virus training conducted by DACT and ASU Employee Health.

B. Physical hazards

Sharps such as needles, broken glass, syringes, pipettes, and scalpels are all commonly found in animal facilities and laboratories and present a physical hazard. Use extra care to avoid inadvertent contact and injury. **Needlestick injuries** represent substantial risk of

becoming infected especially when injecting animals with microbial agents or drawing blood.

The animal facility should have puncture-resistant and leak-proof containers for disposal of sharps. To prevent needle sticks, it is critical to **always place used needles directly into the sharps container without recapping or attempting to bend, shear, break or remove the needle from the syringe.**

Animal care operations involve several activities that can cause physical stress when handling and moving heavy loads. The use of proper lifting techniques can help prevent back and shoulder injuries when moving cages, bags of feed and bedding, pieces of equipment, and supplies. Poor physical fitness, obesity, poor posture, smoking, and medical/physical deficiencies are personal factors that may contribute to back pain. When lifting heavy loads, every attempt should be made to avoid sudden movements and use a two-handed lifting technique. Keep your back straight, feet positioned apart with one slightly ahead of the other, and knees bent as the lift is completed. Reduce loads where possible and get help when lifting awkward loads or those that cannot be handled safely by one person.

C. Chemical hazards

Personnel involved in the care and use of research animals must be familiar with the **chemical hazards** associated with the animal care and laboratory environment. Chemical properties may include flammability, corrosiveness, reactivity, or the potential to be explosive. Potentially hazardous chemicals used in animal laboratories include **solvents** (e.g., xylene, acetone, dimethyl sulfoxide), **acids** (hydrochloric, sulfuric), **bases** (e.g., sodium hydroxide, quaternary disinfectants), **fixatives** (e.g., formaldehyde, osmium tetroxide), **sterilants** (e.g., peracetic acid, chlorine dioxide, peroxides, gluteraldehyde), and **anesthetics** (e.g., isoflurane, tribromoethanol, methane sulfonate, nitrous oxide, urethane, barbiturates). Each chemical product should be handled carefully using the label directions and recommended PPE in accordance with University guidelines and lab training. Safety Data Sheets, or SDSs are also available in each animal facility. These provide additional information on the hazards and precautions related to a chemical's use. Users must be certain that they understand the proper use of the chemical material before they use it.

D. Animal allergies

Allergic reaction to animals is among the most common conditions that adversely affects worker health. The estimated prevalence of allergic symptoms among workers exposed to animals is from 10% to 40%. Workers who are continually exposed to animal allergens tend to have progressively more frequent and severe symptoms, and an estimated 10% develop **asthma**. Hence, it is critical that all workers seek to minimize their exposure to animal allergens. Additionally, once animal allergy develops, the affected worker should minimize any additional allergen exposure to prevent progression of allergy symptoms.

Allergy is most often manifested by **nasal symptoms** (e.g., allergic rhinitis), **itchy eyes** (e.g., allergic conjunctivitis), and **rashes** (e.g., contact urticaria, atopy). Symptoms usually evolve over a period of 1-2 years and may lead to acute anaphylaxis in a small number of patients. In **rodents**, the allergen protein is of urinary origin and in **rabbits** it is contained in the fur, dander, and, to a lesser degree, the saliva and urine. In **Guinea pigs**, urine is the main allergen with dander, fur, and saliva contributing. Exposure to **birds** can cause rhinitis and asthma symptoms. Multiple bird proteins have been identified as allergens and can be found in serum and fecal droppings that contain serum. **Fish** proteins can be an inhalation allergen for those who are sensitized. Proteins in dander, saliva, urine and sweat from **dogs** and **cats** may cause allergic symptoms. Although not common, there are

documented cases of individuals developing allergies to **reptile** scales (iguana and lizards). Allergies to livestock including **horses, cattle, pigs, sheep** and **goats** are also common with the allergens contained in dander, saliva and urine, as well as the feed in livestock.

Prudent efforts to prevent allergen exposure and reduce the frequency of sensitization in animal workers require strict work practices and consistent use of PPE. Housing animals in filter-top cages, working in well-ventilated areas, and using ventilated hoods for soiled bedding disposal will minimize exposure to animal allergens.

The work area must be maintained clean to prevent inhalant and contact exposure. Procedures should be adopted that minimize release of airborne materials, including bedding dust and antibiotic aerosols, and the contamination of hands, arms, body, and face. Workers should adopt the use of PPE during each animal contact or allergen exposure. Wearing PPE “just some of the time” will not prevent exposure. Of particular importance is wearing a facemask or respirator to reduce inhalation and hand- to-face spread of allergens and covering all exposed skin (e.g., gloves, lab coat, sleeve protectors, and hair cover) to prevent allergen contact.

It is also important that once animal procedures are complete, all contaminated PPE and clothing are removed and properly disposed of to prevent repeated exposure while performing subsequent duties. Supervisors or EHS can provide further information and access to approved PPE devices.

E. Latex gloves and related allergies

Allergic reactions to natural rubber latex have been increasing since 1987, when the Centers for Disease Control recommended the use of universal precautions to protect against potentially infectious materials, bloodborne pathogens, and HIV. Increased glove demand also resulted in higher levels of allergens due to changes in the manufacturing process. In addition to skin contact with the latex allergens, inhalation is another potential route of exposure. Latex proteins may be released into the air along with the powders used to lubricate the interior of the glove.

In June 1997, the National Institute of Occupational Safety and Health (NIOSH) issued an alert, [“Preventing Allergic Reactions to Latex in the Workplace”](#) (publication number DHHS (NIOSH) 97-135).

NIOSH studies indicate that 8-12% of healthcare workers regularly exposed to latex are sensitized, compared to 1-6% of the general population. Latex exposure symptoms include skin rash and inflammation, respiratory irritation, asthma, and shock. The amount of exposure needed to sensitize an individual to natural rubber latex is not known, but when exposures are reduced, sensitization decreases.

NIOSH recommends the following actions to reduce exposure to latex:

- If latex gloves must be used, choose reduced-protein, powder-free latex gloves.
- Wash hands with mild soap and water after removing latex gloves.
- Whenever possible, substitute another glove material.

When using antibiotic materials, procedures should be adopted that minimize release of airborne materials and skin contamination. Of particular concern are releases of penicillin-type (or other) antibiotics during syringe-loading from multi-dose vials. Persons who have had previous exposures and have developed sensitivity can quickly go into anaphylactic shock after inhaling a mist of antibiotic material. Be sure to handle these materials with

caution and according to use directions. Use and caution inserts for each antibiotic are provided in the product packaging and should be read and understood prior to use. Investigators inexperienced in conducting these types of experiments should seek help in designing their experiments from individuals who are experienced in this special work.

XX. Zoonoses

Zoonoses are diseases that can be transmitted between species (in some instances, by a vector) from animals to humans or from humans to animals (the latter is sometimes called reverse zoonosis or anthroponosis). They may be a significant exposure hazard in some laboratories where animals are used for research. Fortunately, many laboratory animal species today are bred to be free of zoonoses that were once more common in these animals. However, there remain zoonotic agents associated with laboratory animals, some which can be life-threatening. Field research with wild species also remains a clear source of zoonoses exposure. Prevention of exposure to these animal-related illnesses requires knowledge of the zoonoses related to the animals involved. In the sections that follow, the zoonotic agents listed for each animal species are those that may be present in the animals being used. If someone is exposed through bite, scratch, aerosol droplet, mucosal secretion, feces, or urine, there is the potential for infection, so medical consultation through ASU Employee Health is highly recommended.

A. Rodents

Modern laboratory mice and rats are bred to exclude all zoonotic agents, including Rat bite fever. Also, mice received at ASU from foreign countries have been tested during quarantine for many infectious and zoonotic agents. Therefore, unless the laboratory mice and rats are infected as part of the research procedures or exposed to wild mice (those coming from the natural habitat outside the laboratory), there is limited concern for disease from these research mice. However, there is always concern about secondary infections that can occur with bites and scratches. Common skin, intestinal, and soil bacteria present on a person, or an animal can infect the scratch or bite wound and cause these secondary infections. Therefore, users should handle all laboratory rodents with care and always cleanse any wound immediately with soap and water or antiseptic and seek medical consultation at ASU Employee Health for broken skin.

Wild rodents or laboratory rodents that have been exposed to wild rodents have the potential of carrying a variety of zoonotic bacteria and viruses that can be passed on to workers handling them. Tests should always be completed on wild rodents and those coming from foreign countries when they are received at ASU to screen for these zoonotic agents. Although this provides reasonable assurance that rodents will be free of zoonotic infections, the screening does not guarantee infection-free rodents. Therefore, because of the serious consequences of becoming infected, investigators must always follow good personal hygiene and animal handling procedures and use the provided PPE to protect from exposure. Rodents that have originated from the wild, have had contact with wild rodents, or are from foreign countries could be infected with one or more of the pathogens and should be considered ABSL-2.

Viruses that can cause serious disease in humans include Hantavirus and Lymphocytic Choriomeningitis (LCM) Virus. Hanta virus is transmitted through inhalation of dried rodent feces and urine when such material is raised into the air from disturbed feces, bedding, or nesting material. Transmission can also occur through rodent bites and contamination of broken skin or mucous membranes. The infection progresses from flu-like symptoms to respiratory complications and has resulted in death in over 50% of clinical cases, particularly when medical care was not quickly obtained. It is possible to prevent exposure using PPE, good personal hygiene, and properly ventilated handling of waste bedding material. LCM virus is transmitted to humans by inhalation, broken skin, or mucous membrane exposure to blood, urine, feces, and other body secretions from infected mice. The infection results in flu-like symptoms 1 to 3 weeks after exposure. More severe symptoms of meningitis and encephalitis can result. There is a special risk of exposure during pregnancy because the fetus can become infected. Because mice are well screened and provided from virus-free sources, the potential for exposure in ASU animal facilities is very limited. Again, use of proper PPE, such as disposable gloves and lab coat, along with

careful hand washing will further reduce the likelihood of exposure. In addition, DACT conducts tests for LCM in laboratory bred mice and rats to ensure these animals remain free of the virus.

B. Gerbils, hamsters, and other small rodents

Small rodents such as gerbils, hamsters, and guinea pigs are outbred by commercial vendors as general models for biomedical research. They are often assured as free of infectious pathogens, though it is not impossible for an animal to become infectious after its arrival at ASU facilities. Proper care and hygiene, including PPE, should be utilized for the protection of both researchers and animals.

Diseases of zoonotic concern for these rodents include campylobacteriosis, giardiasis, lymphocytic choriomeningitis virus (LCMV), sarcoptic mange, monkeypox virus, pasteurellosis, rat bite fever, ringworm, and salmonellosis.

C. Laboratory rabbits

Modern laboratory **rabbits** contain few infectious pathogens. Of concern are scratches that can be inflicted with their strong hind legs and sharp claws or from bites. Secondary infection with common skin, intestinal, and soil bacteria present on personnel, or the animal can result, so personnel should always cleanse wounds immediately with soap and water or antiseptic and seek medical consultation for severe wounds.

Historically, laboratory rabbits have been known to harbor the bacteria for human Tularemia (Rabbit Fever). Although this zoonotic agent remains present in wild rabbit populations, modern laboratory rabbits are free of this bacterium. Other infectious agents capable of causing infection in humans that are isolated from laboratory rabbits, particularly when group housed or stressed include *Bordetella bronchiseptica* and *Pasteurella spp.*

D. Birds

The **birds** used in research colonies are either caught in the wild or acquired from established flocks. In general, birds are not supplied disease-free and usually contain several microbial agents including *Mycobacterium avium*. Of zoonotic concern are the diarrheal bacteria such as *Salmonella* and *Chlamydia psittaci*, the bacteria that cause psittacosis, which can cause a more severe type of infection.

Salmonella bacteria is a common contaminant of fecal droppings and eggs. When ingested by humans, this bacterium has the potential for causing severe intestinal disease. Use of good personal hygiene measures including effective and thorough hand washing along with the proper PPE, such as disposable gloves and lab coat, will greatly reduce the likelihood of infection when handling birds and materials in their environment.

The bacterium *Chlamydia psittaci* is the cause of psittacosis, and it is found most widely in large, imported psittacine birds (e.g., parrots, parakeets, cockatoos, and macaws). Human infection is most often the result of exposure to these imported birds. The risk of exposure from domestic birds is very low.

However, because this bacterium is highly infectious, there is some potential that any bird or mammal may be infected. Acute infection in animals causes such symptoms as reddening of the eyes (conjunctivitis), difficulty breathing (pneumonia), swollen painful joints (arthritis), and reproductive problems. After the acute infection, those animals that survive enter a period without symptoms during which stress can cause the animal to shed the bacterium. Stress can result from such things as the importation process or birds being handled in their new environment. Humans can be infected when coming in contact with

the bird's body secretions or feces. In humans, the symptoms include fever, headache, muscle pain, and chills, and may progress to pneumonia as well as liver, heart, and brain inflammation.

USDA regulations require that testing be performed on all psittacine birds imported from foreign countries during an initial 60-day quarantine period. There were no psittacine birds from foreign countries at ASU at the time this document was developed or updated. However, in the event that ASU acquires psittacine birds from a foreign country, they would be quarantined in specially ventilated rooms while testing is done, and infected birds would be eliminated from the colony. The use of protective equipment and thorough hand washing would reduce the risk of any potential exposure.

E. Dogs and cats

Dogs and cats used in research are often acquired from commercial vendors and are considered "purpose-bred" for biomedical research. Facilities that provide these animals should be regulated by the US Department of Agriculture and accredited by AAALAC International, to assure that the highest possible standards of care are met. However, possible zoonotic infections are still possible even with animals that are certified as clean by any vendor.

Diseases carried by dogs often are not easily ascertained through visual inspection. However, these diseases can cause serious illness in humans. Diseases of zoonotic concern include brucellosis, campylobacteriosis, *Capnocytophaga*, cryptosporidiosis, tapeworms, echinococcosis, giardiasis, hookworms, leptospirosis, MRSA, plague, rabies, ringworm, roundworm, salmonellosis, sarcoptic mange, and tickborne diseases.

Cats can carry harmful germs that can cause a variety of illnesses in people, ranging from minor skin infections to serious illnesses. Diseases of zoonotic concern include campylobacteriosis, cat scratch disease, cat tapeworm, cryptosporidiosis, giardiasis, hookworm, MRSA, plague, rabies, ringworm, roundworms, salmonellosis, sporotrichosis, tickborne diseases, and toxoplasmosis.

One of the best ways to prevent illness and protect yourself from getting sick is to thoroughly wash your hands after handling, caring for, feeding, or cleaning up after dogs or cats.

F. Fish, corals, and amphibians

Fish, corals, and amphibians used in research colonies are mostly wild-caught or raised on commercial farms. These animals often contain parasites and bacteria. Of zoonotic concern are gram-negative bacteria that cause secondary infection of contaminated wounds and breaks in the skin. These bacteria include *Aeromonas*, *Pseudomonas*, *Klebsiella*, and *Mycobacteria*. Use of proper PPE, such as disposable gloves, will help prevent contamination of skin surfaces. Likewise, thorough hand washing is very important to further reduce potential for infection.

G. Reptiles

Reptiles carry germs that can make handlers sick, most prominently *Salmonella*, located within the digestive tract of healthy reptiles. Infection from *Salmonella* can cause infections (Salmonellosis) in people who have contact with reptiles and their environments, including the water from terrariums or aquariums where they live. Salmonellosis symptoms include diarrhea, vomiting, fever, or abdominal cramps. Infants, elderly persons, and people with weakened immune systems are more likely than others to develop severe illness.

Other diseases of zoonotic concern include *Aeromonas* and mycobacteriosis. Maintaining good water quality in the home environment, removing any deceased fish that might share the home environment, and practicing good hand washing skills are essential to prevent zoonotic infection.

Additionally, rodents are often used as a source of feed for captive reptiles. These rodents can carry germs that can make people sick, as discussed above. Proper safety precautions should be taken when feeding rodents to reptiles.

H. Livestock

Livestock animals used in research include cattle, sheep, pigs, goats, llamas, and alpacas.

Diseases of zoonotic concern include anthrax, brucellosis, campylobacteriosis, Orf virus (sore mouth infection), cryptosporidiosis, E. coli, influenza, leptospirosis, listeriosis, MRSA, Q fever (*Coxiella burnetii*), rabies, ringworm, and salmonellosis.

Swine flu, such as what caused the 2009 pandemic (H1N1 influenza) can spread between pigs and people. Most reported variant flu virus infections in people have occurred following exposure to infected pigs or their various contaminated environments. The main way flu viruses are thought to be spread are when an infected pig (or person) coughs or sneezes, and droplets containing virus spread through the air. There is also evidence of transmission by touching something that has virus on it and then touching your eyes, nose or mouth. Lastly, possible infection can occur when small particles that contain the flu virus are inhaled.

Most swine flu infections have resulted in mild illness in people, but severe illness or death can occur. Those at high risk of developing serious illness include children younger than 5 and people 65 years of age and older, pregnant women, and people with certain underlying conditions. It is recommended that those at high risk for serious flu complications avoid pigs and pig environments. If you must work around sick people or pigs, use appropriate PPE such as gloves and a face mask or respirator.

To help protect yourself from getting sick, thoroughly wash your hands right after handling farm animals, their supplies, or anything in the areas where they live and roam.

I. Non-Human Primates, or NHPs

Several potentially serious zoonoses are associated with non-human primates. In addition, the strength and unpredictability of non-human primates pose dangers to those handling them. It is critical that work with non-human primates be done while wearing the appropriate personal protective equipment and following the well-established, safe protocols and procedures.

1. Simian B Virus

Simian (Monkey) B Virus is a herpes virus of Old World macaque monkeys. Common macaque monkeys used at ASU include cynomolgus (*Macaca fascicularis*) and rhesus (*Macaca mulatta*) monkeys. However, all macaques can transmit the virus. In non-human primates, this virus causes symptoms similar to human cold sore virus, which includes mouth ulcers during acute infection and long periods of inactivity. Viral activity in the monkey commonly occurs with stress or other disease/conditions; otherwise, they appear completely healthy while shedding large amounts of active virus in the saliva.

When humans are infected, the virus produces flu-like symptoms that can lead to

death within 3-14 days. Therefore, it is critical to be familiar with and follow all the established practices and procedures before beginning work with non-human primates. The virus will survive on contaminated equipment and a few human cases have been documented after workers were scratched by soiled equipment. Fortunately, the virus is susceptible to killing with bleach solutions and other disinfectants used in the animal facility.

All macaques housed at ASU come from sources that provide animals seronegative for the virus. In addition, Arizona law requires that macaques must have negative serology for Herpes Simian B virus within 30 days of entry into the state. Because Herpes Simian B virus is highly fatal in humans if they become infected, all macaques are treated as being potentially infected with the virus should an exposure occur.

ASU Employee Health and DACT have developed a comprehensive program for non-human primate workers at ASU that includes the designation of PPE required for each functional area where non-human primates and potentially contaminated equipment are handled and detailed procedures for medical response and follow-up for injuries associated with non-human primate care and use.

2. Tuberculosis

Tuberculosis, or TB, is caused by bacteria that can be given to and acquired from non-human primates. Tuberculosis is transmitted via water droplets in the air from infected non-human primates and humans. Humans can contract the disease by unprotected exposure to infectious droplets generated by the handling of dirty bedding, the use of high-pressure water sprayers, the coughing of animals with respiratory disease, or contaminated feces of animals with intestinal disease. Likewise, ASU's resident non-human primate colony is susceptible to human tuberculosis that can be transmitted from infected workers.

The prevention and control measures in place involve bi-annual TB testing of each nonhuman primate and the use of PPE that includes respiratory protection. All humans that work with non-human primates are tested by ASU Employee Health annually for TB. Required PPE for working with non-human primates is listed on postings located in each of the areas of non-human primate activity. It is very important that employees understand and follow these posted requirements.

3. Measles

Healthy non-human primates are susceptible to measles from exposure to humans who are shedding the measles virus. The infection in non-human primates is severe and produces rash, fever, malaise, and progressive respiratory distress. There is a vaccine available for use in non-human primates. However, all non-human primate populations should be considered susceptible until proven otherwise. At ASU, all personnel who have contact with NHPs are required to have adequate vaccinations (measles, mumps, rubella [MMR]). There are currently no reliable diagnostic tests to indicate measles infection in non-human primates.

XXI. Emergency response procedures

ASU has a campus-wide emergency response plan, the ASU Emergency Operations Plan, which is compliant with 29 CFR 1910.120. Protocols for handling biological emergencies are outlined in the plan. A summary of this plan can be found by reviewing the ASU [Emergency Procedures Flipchart](#) or the ASU Police Department [Policies and Procedures Manual](#).

Principal investigators must be aware of the provisions for emergency procedures and preparedness. Emergency procedures and preparedness must be incorporated into the Laboratory-Specific Biosafety Manual and used in the laboratory. Each laboratory should have a written emergency plan specifying the appropriate response to potential emergencies. Accidents and spills of infectious materials will be discussed in Emergency Procedures below. In addition, each principal investigator will submit to EHS the following:

- A completed [Responsible Party Information Sheet](#).
- A Health Hazard Assessment for each biological agent and toxin stored or used in the laboratory.
- An annual chemical and biological inventory.

A. Exposures to biohazards

In the event of an exposure to a biohazard, the following guidelines should be used:

1. Intact skin

- Remove contaminated clothing. Clothing should not be pulled over the face as contact with eyes, nose, and mouth may occur.
- Vigorously wash contaminated skin for 1 minute with soap and water. If the use of an emergency shower is necessary washing should be for 15 minutes.
- Call 911 or seek medical attention at the ASU Employee Health, if necessary.
- Inform the laboratory's principal investigator and/or EHS immediately.

2. Broken, cut or damaged skin or puncture wound

- Remove contaminated clothing. Clothing should not be pulled over the face as contact with eyes, nose, and mouth may occur.
- Vigorously wash contaminated skin for 10 minutes with soap and water.
- Call 911 or seek medical attention at the ASU Employee Health, if necessary.
- Inform the laboratory's principal investigator and/or EHS immediately.

3. Eye

- Immediately flush eyes for at least 15 minutes with water, using an eyewash. Hold eyelids away from your eyeball and rotate your eyes so that all surfaces may be washed thoroughly.
- Remove contaminated clothing. Clothing should not be pulled over the face as contact with eyes, nose, and mouth may occur.
- Call 911 or seek medical attention at the ASU Employee Health, if necessary.
- Inform the laboratory's principal investigator and/or EHS immediately.

4. Ingestion or inhalation

- Move to fresh air immediately.
- Call 911 or seek medical attention at the ASU Employee Health, if

necessary.

- Do not induce vomiting unless advised to do so by a health care provider.
- Inform the laboratory's principal investigator and/or EHS immediately.

B. Spills of biohazards (including r/sNA molecules)

ASU does not have a centralized biological spill response team. Therefore, each laboratory working with potentially hazardous biological material must be prepared and trained to handle its own biological spills. EHS is available for assistance if necessary. Additional information pertaining to spills which involve recombinant or synthetic nucleic acid molecules, blood, microorganisms, or any other bioresearch materials can be found at cfo.asu.edu/biological-spill. Performing all work on plastic-backed absorbent liners to absorb spills can minimize the consequences of a spill of a biohazard. The quantities of these materials should be limited so they can be easily contained, cleaned, or destroyed. If respiratory protection is required, the ASU [Respiratory Protection Program](#) must be followed. A simple spill kit with the following supplies should be available and used by trained personnel:

- Bleach or other EPA-registered disinfectant.
- Biohazard bag.
- Disposable lab coat.
- Disposable shoe covers.
- Hand sanitizing wipes.
- Nitrile gloves (4 pair).
- Mini brush and dustpan (or something to scoop spilled materials).
- Paper towels.
- Safety goggles.
- Tong or forceps to pick up broken glass.
- Spray bottle (to make fresh bleach solution).
- "Biohazard Spill" sign.

C. Spills of biohazards inside a biological safety cabinet

- Remain calm and secure research samples.
- Alert the other laboratory employees of the spill.
- Leave the cabinet turned on.
- Pick up any pieces of broken glass with forceps or tongs and place in sharps container. Never use hands.
- Cover the spill with paper towels.
- Pour appropriate disinfectant for example 1:10 bleach solution over the paper towels moving from the outer edges to the middle of the spill.
- Leave the disinfectant for a contact time of 20 minutes.
- Pick up paper towels and discard into a biohazard container.
- Re-wipe the spill area with disinfectant.
- Determine if the spill reached the front or rear grills. If necessary, flood the work surface as well as the drain pans and catch basins below the work surface with appropriate disinfectant.
- Leave disinfectant for a contact time of 20 minutes.
- Drain catch basin into a container.
- Lift front exhaust grill and tray and wipe all surfaces. Ensure that no paper towels or solid debris are blown into the area beneath the grill.

- Dispose cleanup materials in the biohazard waste container.
- Remove PPE and wash hands after the cleanup procedure.
- Report the spill to the laboratory's principal investigator or lab manager.
- The principal investigator or lab manager will report the spill to the Biological Safety Officer.
- Resume work if deemed safe by supervisor/manager.

D. Small spills (<500 mL) of biohazards outside a biological safety cabinet

- Remain calm and make note of whether your person has been contaminated.
- Alert other laboratory employees in the area and block off the area.
- Wearing gloves, safety glasses, and a lab coat, secure container.
- Pick up any pieces of broken glass with forceps or tongs and place in sharps container. Never use hands.
- Cover the spill with paper towels and gently apply appropriate disinfectant, proceeding from the outer edge of the spill to its center. Leave disinfectant for a contact time of 20 minutes.
- Pick up the paper towels and discard into a biohazard container.
- Re-wipe the spill area with disinfectant.
- Remove PPE and wash hands after the cleanup procedure.
- Report the spill to the laboratory's principal investigator or lab manager.
- The principal investigator or lab manager will report the spill to the Biological Safety Officer.
- Resume work if deemed safe by supervisor/manager.

E. Large spill (>500 ml) of biohazards outside a biological safety cabinet

- Remain calm and notify others present in the room to stay out of the spill area to prevent spread of contamination and leave the room.
- Secure container
- Check for contaminated PPE or clothing. Remove contaminated PPE and place in the biohazard waste. Remove any contaminated clothing, ensuring that clothing is not pulled over the face and leave in room for later autoclaving.
- Exit the room.
- Post a sign stating: "Do not enter, biohazard spill, contact (name and phone #) for information" and block off area as possible.
- Wash hands, eyes and exposed skin if needed.
- Notify the principal investigator or supervisor.
- The principal investigator or supervisor will contact EHS immediately.
- Wait 30 minutes before re-entering the contaminated area to allow for dissipation of aerosols.
- Meanwhile, put on protective clothing (lab coat, gloves and, if indicated, respirator, eye protection, shoe covers) and assemble clean-up materials.
- Pick up any broken glass with forceps and place them into a sharps container. Never use hands.
- Cover the spill with paper towels and gently apply disinfectant, proceeding from the outer edge of the spill to its center. Leave disinfectant for a contact time of 20 minutes.
- If needed, place contaminated clothing in a biohazard bag for autoclaving.
- Wipe all the surfaces that may have come in contact with the spilled material with disinfectant.
- Collect all treated material and discard in a biohazard container. Re-wipe the spill area with disinfectant.

- Remove PPE and wash hands after the cleanup procedure.
- Resume work if deemed safe by supervisor/manager.

F. Spill of biohazards in a centrifuge

A single centrifuge spill or release can lead to multiple infections in a laboratory. Aerosols are created when fluid escapes from the rotor or cup while the centrifuge is operating at high speed. Therefore, whenever opening a centrifuge, it must be performed slowly.

1. Unsealed buckets

- If a centrifuge tube breaks while the centrifuge is running, turn off motor. Allow the machine to be at rest for 30 minutes before opening.
- Unplug centrifuge before initiating clean up.
- Put on two pairs of nitrile gloves and other PPE before proceeding with clean up.
- Remove broken tubes and glass fragments using tongs or forceps. Place fragments in a sharps container for autoclaving and disposal as infectious waste.
- Place paper towels over the entire spill area and pour disinfectant over the paper towels. Allow 20 minutes contact time.
- Remove buckets, trunnions, and rotor and place in disinfectant for 20 minutes or autoclave.
- Unbroken, capped tubes may be placed in disinfectant and recovered after 20 minutes contact time or autoclaved.
- Remove remaining disinfectant soaked materials from centrifuge bowl and discard as biohazard waste bag.
- Wipe down again with disinfectant, wash with water and dry. NOTE: Household bleach is a corrosive. Use caution when immersing or having metal components in contact with bleach (sodium hypochlorite) for extended periods of time.
- Remove protective clothing used during cleanup and place in a biohazard bag for autoclaving. Wash hands after the cleanup procedure.
- Notify principal investigator, supervisor, and/or EHS.

2. Sealed buckets | Safety cups

- If breakage of tubes is suspected, remove the sealed bucket/safety cups to a biological safety cabinet before opening. Discard of tubes in biohazard waste and perform cleanup inside of the BSC.
- Notify principal investigator, supervisor, and EHS if there was a potential for any material escaping the centrifuge.

G. Reporting exposures

In the event of an exposure to a biohazard:

- Report to ASU Employee Health or a primary healthcare provider.
- Complete an Accident/Illness Report Form and submit to EHS within 24 hours of incident.
- If exposure or incident occurs with s/rDNA, work with the principal investigator, supervisor, and Biological Safety Officer to report accident to the NIH Office of Biotechnology Activities as required by the NIH Guidelines.

XXII. Permits

The import, export, transfer or interstate movement of biological materials, animals, plants, arthropods, environmental samples, or other materials is strictly regulated by various US federal and international agencies and may require permits or licenses. Failure to comply with regulations and secure the required permits or licenses when importing, exporting, or transporting regulated materials may result in shipment delays or destruction at US ports of entry, refusal of the shipment by carriers, and be subject to fines and/or criminal penalties.

A. CDC Import Permit Program

The CDC Import Permit Program, or IPP, regulates the importation of infectious biological materials that could cause disease in humans in order to prevent their introduction and spread into the U.S. The program ensures that the importation of these agents is monitored and that facilities receiving permits have appropriate biosafety measures in place to work with the imported agents.

Materials requiring import permits include:

- Infectious biological agents capable of causing illness in humans
- Materials known or reasonably expected to contain an infectious biological agent
- Vectors of human disease (such as insects or bats)

B. **USDA Animal and Plant Health Inspection Service (APHIS) Permits**

USDA's Animal and Plant Health Inspection Service, or APHIS, permits are required for the import, transit and release of regulated animals, animal products, veterinary biologics, plants, plant products, pests, organisms, soil, and genetically engineered organisms. See ASU's Animal Research Information for importing live animals for research.

1. **Animal and animal products**

Includes live animals, semen, embryos, and materials derived from animals or exposed to animal-source materials such as animal tissues, blood, cells or cell lines of livestock or poultry origin, RNA/DNA extracts, hormones, enzymes, microorganisms including bacteria, viruses, protozoa, and fungi. In addition, animal materials including dairy products (except butter and cheese), and meat products (e.g., meat pies, prepared foods) from countries with livestock diseases exotic to the U.S.

If you are importing a pet dog or cat, please do not apply for an import permit and contact the [Centers for Disease Control and Prevention \(CDC\)](#) for requirements.

- [Apply for an Import or Transit Permit](#) (Check application status)
- [Export Guidelines and Regulations](#)
- [Import, Organisms and Vectors Guidelines and Regulations](#)
- [Pet Travel Information](#)

2. **Live dogs | Resale**

If you are importing live dog(s) for resale, whether through commercial sale or adoption, please visit [How to Bring Dogs into the United States for Commercial Sale or Adoption](#) for important information about live dog imports.

- There is a [fee](#) to obtain APHIS animal health permits.

3. **Biotechnology permits**

Includes genetically engineered organisms considered to be regulated articles.

- [Learn about BRS Permitting and Notification Process](#)
- [Apply for a BRS Notification or Permit](#)
- A permit application should be submitted to APHIS:
- At least 60 days prior to the first proposed importation or interstate movement.
- At least 120 days in advance of the proposed release into the environment.
- There is no fee to obtain a BRS Permit.

See: [USDA BRS Permits User Guide](#) for additional information.

4. **Plants, organisms and soil**

- [Plant Health Permit Website](#)
- [Obtain a Plant Export Certification](#)
- There is no fee to obtain a Plant Health Permit.

5. **Veterinary biologics**

Includes vaccines, bacterins, antisera, diagnostic kits, and other products of biological origin.

- [Apply for a Veterinary Biologics Permit](#)

C. **Invasive species in Arizona**

There are some targeted Hungry Pests that have federal quarantines in certain areas of Arizona. Other Federal and State quarantines may apply. Arizona has some crop, forest, or urban area(s) where [these pests or diseases](#) could survive year-round.

D. **U.S. Fish & Wildlife Service Permits**

The U.S. Fish & Wildlife Service issues permits under various wildlife laws and treaties at different offices at the national, regional, and/or wildlife port levels. Generally, all wildlife (including parts and products) imported or exported from the United States for any purpose must be declared and cleared through [an authorized wildlife port](#).

Follow the three-step process below to determine if a permit is needed.

1. **Step one: Determine the scientific name of your species**

What is the species of wildlife or plant? To determine whether these regulations apply to your species of interest, you will first need to determine the scientific name (genus and species), as wildlife protections are designated at the species, or sometimes the subspecies level.

For example, the scientific name of the monk parakeet is genus *Myiopsitta*, species *monachus*, or "*Myiopsitta monachus*," the scientific name of Brazilian rosewood is genus *Dalbergia*, species *nigra*, or "*Dalbergia nigra*" and the scientific name of the hawksbill sea turtle is genus *Eretmochelys*, species *imbricata* or "*Eretmochelys imbricata*." The scientific name of the Sumatran tiger is genus *Panthera*, species *tigris*, subspecies *sumatrae*, or "*Panthera tigris sumatrae*."

Ask a veterinarian, scientist or [qualified appraiser](#) to help you determine what type of wildlife or plant you have. You may also be able to find the scientific name online.

2. **Step two: Determine how your species / specimen is protected**

Once you know the scientific name of your species of interest determine whether the species is protected under each U.S. or international law. Keep in mind that a species may be listed under multiple laws, so multiple authorizations may be required. If more than one type of permit for an activity is required by multiple regulations, we may be able to issue one consolidated permit authorizing the activity, provided certain criteria are met. Please start by checking the following species lists:

- CITES - Search by scientific name or common name in the [list of CITES species](#).
- Endangered Species Act, or ESA - Visit the U.S. Fish & Wildlife Service's [Endangered Species program website](#).
- Marine Mammal Protection Act, or MMPA - The U.S. Fish and Wildlife Service has jurisdiction over the walrus, polar bear, sea otter, marine otter, West African manatee, Amazonian manatee, West Indian manatee, and dugong. All other marine mammals are regulated by the [National Oceanic and Atmospheric Administration \(NOAA\) Fisheries](#). [Learn more](#) about marine mammal permits.
- Wild Bird Conservation Act, or WBCA - [See the species listed under the Wild Bird Conservation Act](#).
- Lacey Act - Check the [current list of injurious wildlife](#). Injurious wildlife are species, including offspring and eggs, designated through regulation to be injurious to the health and welfare of humans, the interests of agriculture, horticulture or forestry, and the welfare and survival of wildlife resources of the United States. Species, including offspring and eggs, designated through regulation to be injurious to the health and welfare of humans, the interests of agriculture, horticulture or forestry, and the welfare and survival of wildlife resources of the United States. Please see our guidance if you are a [constrictor snake owner](#). Also see the Fish and Aquatic Conservation Program's Injurious Wildlife [webpage](#).
- Migratory Bird Treaty Act, or MBTA - [View the list of MBTA protected birds](#).

3. **Step three: Discover which application you need**

What activity do you seek to conduct? Generally, if you seek to conduct import, export, take, or conduct interstate or international commercial activities and your species of interest is protected under domestic or international law but can also be legally traded, the next step is to apply for a permit. First find [the permit application you need](#).

Please note: if your specimen is only protected under CITES Appendix II or III and you are traveling with or moving your personal belongings, you may meet the requirements of [the CITES personal and household effects exemption](#).

If you already know that your species of interest or your activity do not meet the criteria of the CITES personal and household effects exemption, such as all commercial endeavors, all CITES Appendix-I, ESA, WBCA, MMPA, and MBTA protected species, and species listed as Injurious Wildlife under the Lacey Act, a permit is required.

Are you now ready to apply for a permit? If so, you can [search for the application you need](#) and you can also review our tips on completing application forms.

E. Agreements with ASU

In addition to permits, agreements or licenses may be required. For more information contact the [Agreements with ASU Office](#).

XXIII. Transfers, packaging, and shipping of biological materials

A. Transfers

The transferring, packing, and shipping of select agents and toxins is **highly** regulated. No select agent or toxin shall be transferred, packed, or shipped without the express approval from the RO. Please contact the ASU Biological Safety Officer for more information.

For materials that are not select agents, each principal investigator must develop procedures for transferring or shipping from the laboratory. The principal investigator must ensure the following:

- Personnel who package, handle, and ship non-select agents and biohazardous materials (including import and export) are subject to all applicable training. Please refer to [EHS Policy 406](#). The RO must be notified of all select agent transfers; internal or external.
- Standard operating procedures should be in place for all import and export activities.
- Package, label, and transport biohazards in compliance with all applicable local, federal, and international transportation and shipping regulations, including U.S. Department of Transportation, or DOT, regulations. Materials that are transported by airline carrier should also comply with packaging and shipping regulations set by the International Air Transport Association, or IATA.
- Required permits (e.g., granted by the U.S. Public Health Service, USDA, FWS, DOT, U.S. Department of Commerce, and IATA) are obtained before biohazards are prepared for transport.
- Decontaminate contaminated or potentially contaminated materials before they are removed from the laboratory area.
- Avoid hand-carrying biohazards when transferring them to other external facilities. If biohazards are to be hand-carried on common carriers, all applicable packaging, transport, and training regulations should be followed.
- Develop and follow a protocol for intra-facility transfer (between laboratories on ASU campuses) of all biological and biohazards. Contact EHS for assistance.
- Packaging and shipping of biological materials must be completed in a way that ensures the contents will not leak and that the package will arrive in good condition.

B. Packaging

All biological materials including diagnostic specimens and biological products that may contain an etiologic/biohazardous agent must be packaged to withstand leakage of contents, shocks, pressure changes and other conditions possible with ordinary handling and transportation (e.g., passage through cancellation machines, sorters, conveyors). Contents should not leak to the outside of the shipping container even if leakage of the primary container occurs.

Specific packaging requirements apply to materials that are known to contain, or reasonably believed to contain certain etiologic agents. For such materials the following procedures apply (See Figure 4. Source: [Biosafety in Microbiological and Biomedical Laboratories 6th Edition](#)).

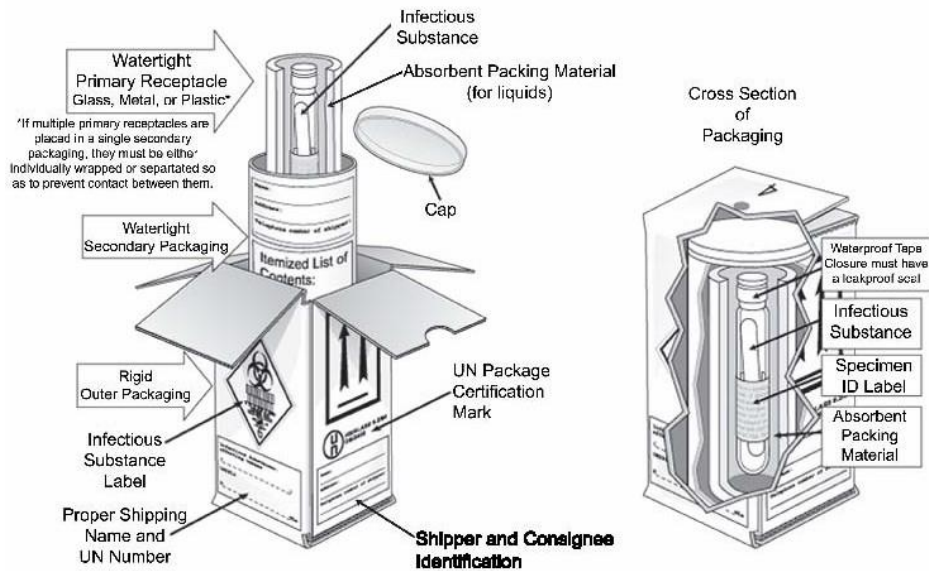

Figure 4. Packaging diagram for biohazards

C. Packaging volumes

1. Volume not exceeding 50 milliliters (ml)

- Place material in a securely enclosed, watertight primary container (e.g., test tube, vial). Enclose this primary container in a secondary, durable, watertight container. Several primary containers may be enclosed in a single secondary container as long as the total volume of material in all the primary containers enclosed does not exceed 50 ml.
- Place absorbent non-particulate material (e.g., paper towels, not sawdust or vermiculite) in the spaces at the top, bottom, and sides between the primary and secondary containers. Use enough absorbent material to absorb the entire contents of the primary container(s) in case of breakage or leakage.
- Enclose each set of primary and secondary containers in an outer shipping container constructed of corrugated fiberboard, cardboard, wood or other material of equal strength. Do not use bags, envelopes, or similar materials.
- If you package the material with dry ice, see the Packaging with Dry Ice section in this document.

2. Volume greater than 50 ml

- Follow requirements for lesser volumes outlined above.
- Place shock absorbent material at the top, bottom, and sides between the secondary container and the outer shipping container. (This material should at least equal the amount of absorbent material placed between the primary and secondary containers).
- Ensure single primary containers contain no more than 1000 ml of material; however, two or more primary containers (combined volumes not exceeding 1000 ml) may be placed in a single secondary container. The maximum amount of etiologic agent which may be enclosed within a single outer shipping

container must not exceed 4000 ml.

D. Packaging with dry ice

- If used, place dry ice between the secondary and outside containers.
- Place shock absorbent material to prevent the secondary container from becoming loose inside the outer container as the dry ice sublimates.
- Use the DOT dry ice label. Guidelines for shipping are available by contacting EHS.

E. Labeling

The outer shipping container of all materials containing etiologic/biohazards which are being shipped or transported must bear a special label. Please **contact EHS** for more information about shipping labels.

F. Shipping and transportation methods and requirements

1. Registered mail or the equivalent

For a list of etiologic agents that use registered mail or an equivalent system which provides the sender with immediate notification of receipt refer to the CDC Select Agent [website](#).

2. Federal Express or UPS

- For Federal Express/UPS shipments, internationally or domestically, follow the International Air Transport Association (IATA) Dangerous Goods Regulations. (Receipt of shipment notice is not required since the shipment is traceable through the specific carrier.)
- Apply appropriate labels to the outer shipping container for packages containing dry ice and/or biohazard as shown in Figures 5 and 6, respectively.
- Contact the specific carrier's dangerous goods agent prior to shipment for any additional packaging and labeling requirements.

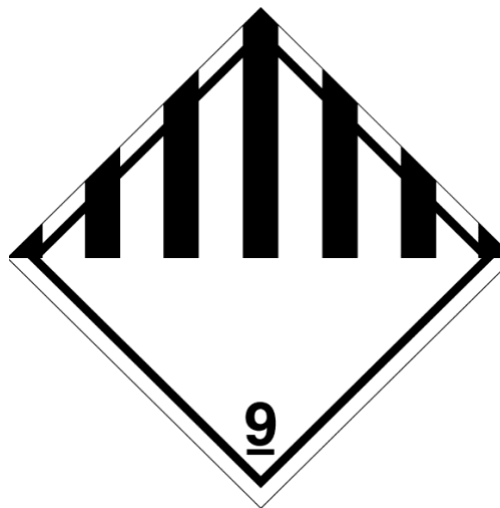

Figure 5.



Figure 6.

3. **Damaged packages**

When evidence of leakage or any other damage to packages bearing an Etiological Agents/Biomedical Material label is discovered, the carrier must promptly isolate the package and notify the Director, Centers for Disease Control and Prevention (CDC), 404.633.5313, 1600 Clifton Road NE, Atlanta, Georgia 30333.

4. **Notice of delivery**

If a package sent from ASU is not received by the recipient within 5 days following the anticipated delivery of the package, the sender must notify the Director, Centers for Disease Control and Prevention, 1600 Clifton Road NE, Atlanta, Georgia 30333 or by telephone 404.633.5313.

5. **Importation/exportation of etiologic agents**

Importation of biohazards, etiologic agents, and vectors that may contain such agents is governed by federal regulation. In general, an importation permit is required for any infectious agent known to cause disease to humans. This includes, but is not limited to, bacteria, viruses, rickettsia, parasites, yeasts, and molds. In some instances, an agent that is suspected of causing human disease also requires a permit.

There are two main import permit types for biologically hazardous agents and vectors: U.S. Public Health Service, or USPHS; and Centers for Disease Control and Prevention, or CDC.

a) U.S. Public Health Service

Importation permits are issued by the U.S. Public Health Service, or USPHS, only to the importer, who must be in the United States. The importation permit, with the proper packaging and labeling, will expedite clearance of the package of infectious materials through the USPHS Division of Quarantine and release by U.S. Customs.

b) CDC Application for Permit to Import Infectious Biological Agents into the United States

Code of Federal Regulations Title 42 Chapter I Subchapter F Part 71 Subpart F §71.54 requires persons importing etiologic agents to obtain a permit through the CDC.

The permits offered by the CDC include Permit to Import Biological Agents or Vectors of Human Disease (A/BSL 2 and A/BSL 4; and ACL-2 and ACL- 3) or Permit to Import or Transport Live Bats. Checklists for compliance with the requirements of the import permit regulations can be found on their [website](#).

Instead of an importation permit, a Letter of Authorization may be issued by the Centers for Disease Control and Prevention after review of an "Application to Import an Etiological Agent." The letter is issued for materials that are judged to be noninfectious, but which U.S. Customs inspection personnel might construe to be infectious. Letters of Authorization may be issued for items such as formalin-fixed tissues, sterile cell cultures, clinical materials such as human blood, serum, plasma, urine, cerebrospinal fluid, and other tissues or materials of human origin when there is no evidence or indication that such materials contain an infectious agent. Letters of Authorization are in effect for two years

and do not require a shipping label to be issued by CDC.

Importation permits and Letters of Authorization are issued by the Biosafety Branch, Office of Health and Safety, CDC, 1600 Clifton Road, Atlanta, Georgia 30333, after review of a completed application form. Application forms may be obtained [online](#) or by calling CDC at their fax Information System. Dial 1-888-CDC-FAXX and enter document number 101000. CDC can also be contacted on their [website](#). Completed forms may be returned to CDC by mail or fax at 404-639-2294. Application to CDC for the importation permit should be made 15 working days in advance of the shipment date to allow time for processing, issuance, and delivery of the permit and shipping labels to the permittee.

G. Other permits

Imported shipments may require a United States Department of Agriculture, or USDA, permit if your product contains ingredients derived from plants or animals or if there is domestic shipping of infectious agents of livestock, poultry and other animal diseases, and any materials that might contain these agents. Most of the plant- or animal-derived ingredients do require a permit. It is better to apply for a permit and receive a Letter of No Jurisdiction than to have a shipment delayed or rejected for lack of a proper permit.

XXIV. Food and beverages in the laboratory

In order to reduce potential exposures and to ensure compliance with prudent laboratory operations, regulations, and other best management practices, ASU prohibits the storage and consumption of food and drink in all designated laboratory space. The only exception is for food and beverages used in research and teaching projects. These materials must be labeled, "Not for Human Consumption."

In order to prevent potential exposure to hazardous materials:

- Do not eat, drink, smoke, chew gum, apply cosmetics, or take medicine in laboratories where hazardous materials are handled or stored.
- Do not store food, beverages, cups, or other drinking and eating utensils in areas where hazardous materials are handled or stored.
- Do not use glassware for laboratory operations to prepare or consume food or beverages.
- Do not use laboratory refrigerators, ice chests, cold rooms and ovens for food storage or preparation.
- Do not use laboratory water sources or deionized laboratory water for drinking water.

Important: Food and beverages must never be stored in any laboratory refrigerator in which chemicals, biological, and radioactive materials are kept unless they have been labeled, "Not for Human Consumption."

XXV. Nails and jewelry

Principal Investigators at ASU are responsible for ensuring that laboratory personnel maintain appropriate hand and nail hygiene. Hands should be kept clean and washed frequently (e.g., after completing work, after removing gloves, before leaving the laboratory). Jewelry should be kept to a minimum to prevent puncturing or otherwise compromising protective gloves or limiting dexterity. CDC, NIH and WHO recommends nail length should be no longer than 0.25 inch beyond the end of fingertips. Artificial nails (e.g., nail extensions, nail wraps, nail jewelry) are not recommended when working in the laboratory.

XXVI. Protective clothing beyond the laboratory

The improper use or lack of protective clothing and equipment in a laboratory can lead to chemical burns, biological exposures, or other potential dangers. To help reduce the risk of exposure, personnel in ASU laboratories are required to wear gloves, safety glasses, lab coats and other personal protective clothing. However, in public areas, such as hallways and lounges, wearing personal protective clothing and equipment is not recommended. This is because contaminated clothing may present a hazard, and the perception of contaminated protective clothing and equipment in a public area may project a careless image to both colleagues and visitors.

Wearing gloves outside the laboratory should be minimized, except to move hazardous materials between laboratories. Chemicals should be transported from place to place on a cart, in a clean secondary container, or in a bottle carrier with secure handles. When this is not an option, personnel should use a clean, ungloved hand to touch common surfaces and a gloved hand to carry the items: the one-glove rule. Alternatively, the material should be packaged so the outer container may be transported without the need for personal protective equipment.

Protective gloves should never come into contact with door handles, elevator buttons, telephones, lavatory faucets, vending machines, bottled water dispensers, ice-making machines, or other surfaces outside the laboratory. Also, please be aware that strict federal and state regulations address the transport of hazardous (e.g., biological, chemical, radiological) materials on public roads.

For the sake of safety, appearances, and courtesy, personnel are asked not to wear contaminated, stained, or potentially contaminated lab coats and other research clothing and equipment in any public area, especially dining areas, lounges, auditoriums, conference rooms, or other non-hazardous areas.

XXVII. Laundering laboratory clothing

Laboratory coats/gowns and contaminated clothing or clothing suspected to be contaminated with chemicals or biohazards are never be taken home or to a public laundry facility.

A. ASU laundry facilities

Laundry facilities exist in a few departments at ASU. Follow departmental procedures for cleaning mild to moderately contaminated clothing. Generally, these facilities are for intra-department use only. Laboratory managers may launder mildly contaminated clothing using departmental laundry facilities where available. Contaminated clothing shall be washed, at a minimum in accordance with the manufacturer's directions. However, departments are encouraged to launder contaminated clothing in hot water (160° F or greater). Where departmental facilities are not available, contaminated clothing must be laundered by a professional laundry service.

B. Professional laundering services

A professional service company may be used if the department does not have the capability to wash mild to moderately contaminated clothing. It is each laboratory's responsibility to determine if the cleaning company is capable and willing to launder the contaminated clothes. Where departmental facilities are not available, contaminated clothing must be laundered by a professional laundry service. Laboratory managers shall ensure that all laundry sent off-site is containerized in leak-proof bags or boxes marked with the biohazard symbol and shall advise the vendor that the laundry is contaminated with blood and/or potentially infectious bodily fluids for textiles that are mildly contaminated.

C. Laundering of personal clothing

Clothing contaminated with biohazardous material must be autoclaved prior to laundering at home. Documentation of effective autoclaving must be maintained. **Note:** Personal laundering is not acceptable for clothing contaminated with chemicals, blood, blood products, or other bodily fluids.

D. Overtly contaminated clothing

Clothing that is overtly contaminated with chemicals must be disposed as hazardous waste. Clothing contaminated with radiological material must be disposed as radiological waste. Clothing that is contaminated with blood, blood products, or other bodily fluids must be removed and containerized in leak-proof bags or boxes at the location where it was used. Containers or bags must be marked with the biohazard symbol.

E. ASU Lab Coat Laundering Program

ASU Environmental Health and Safety provides a free [laboratory coat laundering service](#) to ASU students, faculty and staff in coordination with [ASU Mail Services](#) and [Mission Linen](#). Submit your lab coat through your department's designated laundry bin or U.S. Mail.

XXVIII. Safety audits

ASU Environmental Health and Safety will conduct regular (e.g., annual) inspections of each laboratory to ensure compliance with the procedures and protocols of this manual. Any significant concerns will be reported to the Institutional Biosafety Committee.

The safety audit typically includes an evaluation of the autoclave, biological safety cabinet, microbiological techniques, emergency and safety equipment, storage of biohazardous material, general housekeeping, and review of the Laboratory-Specific Biosafety Manual. Please refer to the ASU Biosafety and Biosecurity [inspection checklists](#), for more information about the biosafety audit form used by EHS.

EHS will make every attempt to schedule safety audits with faculty members. However, if the principal investigator is unavailable or is unresponsive, EHS will proceed with the safety audit. EHS may also conduct unannounced accident investigations. Please be aware that federal, state, and local inspectors may also conduct unannounced inspections.

Following the biological safety survey, a report listing the safety concerns is sent to the faculty member responsible for the laboratory. The faculty member is responsible for correcting the hazards. If the faculty member fails to correct the hazard, a second notice is sent to the department head with a copy to the faculty member. Follow-up audits may be conducted in laboratories with extremely hazardous conditions and/or numerous concerns.

XXIX. Security

Laboratory security is an integral part of an effective safety program. Follow these steps to ensure a secure working environment in your laboratory:

- Keep laboratory doors closed and locked when unoccupied.
- Keep stocks of organisms and hazardous chemicals locked when the laboratory is unoccupied.
- Keep an accurate record of chemicals, stocks, cultures, project materials, growth media and those items that support project activities.
- Notify ASU police if materials are damaged or missing from laboratories.
- Inspect all packages arriving at the laboratory.
- When research is completed for the day, ensure that chemicals and biological materials have been stored properly and securely.
- Decontaminate materials and work surfaces after completing work and at least daily.
- Turn off equipment, flames, steam supply and electrical appliances after completing work.
- Ask strangers (someone you do not recognize as a co-worker or support staff person) to exit the room if they are not authorized to be there.
- Discuss other security-specific requirements with your supervisor and colleagues.

XXX. Working alone

All faculty, staff, students, and visitors working[‡] in an area (e.g., laboratory, animal holding room) where hazardous conditions exist should have knowledge of the following:

- Emergency contacts.
- Emergency response procedures.
- Evacuation routes.
- First aid procedures.
- Health and safety training requirements.
- Personal protective equipment requirements.
- Procedures to report unhealthy and unsafe conditions.
- Safety policies and procedures.
- Spill response equipment and procedures.

All personnel working alone in a laboratory where hazardous conditions exist should:

- Ensure that a means to contact emergency response personnel is available when working alone in the laboratory.
- Obtain written permission (e.g., e-mail, letter) from the PI or laboratory supervisor to work alone in the laboratory.
- Require that individuals working alone contact their supervisor before beginning work and upon completion.

Note: According to the National Safety Council, the term “alone” means that a person is beyond the visual or auditory range of any other individual for more than a few minutes at a time.

XXXI. Recordkeeping

The principal investigator must maintain the following records and be prepared to present these at the annual laboratory inspection:

- A current [Responsible Information Party Sheet](#).
- A Health Hazard Assessment for each biological agent or toxin stored in that room.
- An accurate, current list of each biological agent or toxin stored in that room stored in freezers, refrigerators, dehydrated storage or otherwise.
- [Training Documentation Forms](#).
- Safety, security, and emergency response plans.
- Safety and security incident reports.

XXXII. Program evaluation

The review of the elements as noted in the Recordkeeping sections of this document will constitute an evaluation of the ASU Biosafety and Biosecurity Program.

Appendix A - Definitions

Animals: Any member of the animal kingdom except a human including an animal product (e.g., a mount, rug or other display item composed of the hide, hair, skull, teeth, bones, or claws).

Arthropods: Any living insect including crustaceans, spiders, scorpions, etc. capable of being a host or vector of human disease.

Biohazard: Any microorganism (including, but not limited to, bacteria, viruses, fungi, rickettsia, protozoa, or prions) or infectious substance, or any naturally occurring, bioengineered, or synthesized component of any such microorganism or infectious substance, capable of causing:

- Death, disease or other biological malfunction in a human, animal, plant or another living organism;
- Deterioration of food, water, equipment, supplies, or material of any kind; or
- Deleterious alteration of the environment.

Biological product: A biological prepared and manufactured in accordance with regulations that govern the manufacture of vaccines, reagents, etc.

Centers for Disease Control and Prevention (CDC): The Centers for Disease Control and Prevention of the United States Department of Health and Human Services.

Diagnostic specimen: Any human or animal material including, but not limited to, excreta, secretions, blood and its components, tissue, and tissue fluids, etc., which is reasonably believed to contain an etiologic agent and is being shipped for purposes of diagnosis.

Etiologic agent: A viable microorganism or its toxin that causes, or may cause, human disease

Infectious substance: Any material that is known or reasonably expected to contain a biohazard.

Interstate shipping: Transporting across state lines within the continental United States.

Intrastate shipping: Transporting within the State of Arizona.

Recombinant or synthetic nucleic acid (r/s NA) molecules:

- Molecules that are constructed outside living cells by joining natural or synthetic nucleic acid segments to nucleic acid molecules that can replicate in a living cell, or
- Molecules that result from the replication of those described above, and
- Synthetic nucleic acid segments which are likely to yield a potentially harmful polynucleotide or polypeptide.

Responsible Official: The individual designated by an institution to act on its behalf. This individual must have the authority and control to ensure compliance with the regulations.

Toxin: The toxic material or product of plants, animals, microorganisms (including, but not limited to, bacteria, viruses, fungi, rickettsia, or protozoa), or infectious substances, or a recombinant or synthesized molecule, whatever their origin and method of production, and includes:

- Any poisonous substance or biological product that may be engineered as a result of biotechnology produced by a living organism; or
- Any poisonous isomer or biological product, homolog, or derivative of such a substance.

Vector: Any animals (vertebrate or invertebrate) including arthropods or any noninfectious self-replicating system (e.g., plasmids or other molecular vector) or animal products (e.g., a mount, rug, or

other display item composed of the hide, hair, skull, teeth, bones, or claws of an animal) that are known to transfer or are capable of transferring an infectious biological agent to a human.

Appendix B - Acronyms

AC	Animal Care
APHIS	Animal and Plant Health Inspection Service
ASU	Arizona State University
BMBL	Biosafety in Microbiological and Biomedical Laboratories
BSC	Biological Safety Cabinet
BSO	Biological Safety Officer
CDC	Centers for Disease Control and Prevention
CFR	Code of Federal Regulations
DACT	Department of Animal Care and Technologies
DEA	Drug Enforcement Administration
EHS	Environmental Health and Safety
IACUC	Institutional Animal Care and Use Committee
IBC	Institutional Biosafety Committee
NHP	Non-Human Primate
NIH	National Institutes of Health
OBA	Office of Biotechnology Activities
OLAW	Office of Laboratory Animal Welfare
ORIA	Office of Research Integrity and Assurance
OSHA	Occupational Safety and Health Administration
PHS	Public Health Service
PI	Principal Investigator
PPE	Personal Protective Equipment
SDS	Safety Data Sheet
USDA	United States Department of Agriculture

Appendix C - Disinfection Tables

Disinfectant activity											
Disinfectants		Practical requirements					Inactivates				
Type	Category	Use dilution	Contact time (min) lipovirus	Contact time (min) broad spectrum	Temperature (C°)	Relative humidity (%)	Vegetative bacteria	Lipoviruses	Nonlipid viruses	Mycobacteria	Bacterial spores
Liquid	Quaternary ammonia compounds	0.1%-2.0%	10	NE			+	+			
	Phenolic compounds	1.0%-5.0%	10	NE			+	+	B		
	Chlorine compounds	500 ppm*	10	30			+	+	+	+	+
	Iodophor	25-1600 ppm*	10	30			+	+	+		
	Alcohol, Ethyl	70%-85%	10	30			+	+	B		
	Alcohol, Isopropyl	70%-85%	10	30			+	+	B		
	Formaldehyde	0.2%-8.0%	10	30			+	+	+	+	+
	Glutaraldehyde	2%	10	30			+	+	+	+	+
Gas	Ethylene Oxide	8-23g/ft ³	60	60	37	30	+	+	+	+	+
	Paraformaldehyde	0.3 g/ft ³	60	60	>23	60	+	+	+	+	+

NE=not effective B=Variable results dependent on virus

*=Available halogen (1:100)

Disinfectant characteristics												
Disinfectants		Important characteristics										
Type	Category	Effective shelf life >1 week (A)	Corrosive	Flammable	Explosion potential	Residue	Inactivated by organic matter	Compatible for optics (D)	Skin irritant	Eye irritant	Respiratory irritant	Toxic (E)
Liquid	Quaternary ammonia compounds	+					+	+	+	+		+
	Phenolic compounds	+	+			+			+	+		+
	Chlorine compounds		+			+	+		+	+	+	+
	Iodophor	+	+			+	+		+	+		+
	Alcohol, Ethyl	+		+						+		+
	Alcohol, Isopropyl	+		+						+		+
	Formaldehyde	+				+			+	+	+	+
	Glutaraldehyde	+				+		+	+	+	+	+
Gas	Ethylene Oxide	N/A		+(B)	+(B)			+	+	+	+	+
	Paraformaldehyde	N/A		+(C)	+(C)			+	+	+	+	+

N/A=not applicable (A) =Protected from light and air (B) =Neither flammable nor explosive in 90% CO₂ or fluorinated hydrocarbon, the usual form (C) =At concentrations of 7%-73% by volume in air, solid exposure to open flame (D)=Usually compatible but consider interferences from residues and effects on associated materials such as mounting (E)=By skin or mouth, or both. Refer to manufacturer's literature and the MSDS.

Disinfectant applications												
Disinfectants		Important characteristics										
Type	Category	Work surface	Dirty glassware	Large area	Air handling	Portable equip. surface decon	Portable equip. penetrating decon	Fixed equip. surface decon	Fixed equip. penetrating decon	Optical and electronic inst.	Liquid and discard	Book, paper
Liquid	Quaternary ammonia compounds	+	+			+		+				
	Phenolic compounds	+	+			+		+				
	Chlorine compounds	+	+			+		+			+	
	Iodophor	+	+			+		+				
	Alcohol, Ethyl	+	+			+		+				
	Alcohol, Isopropyl	+	+			+		+				
	Formaldehyde	+	+			+		+				
	Glutaraldehyde	+	+			+		+				
Gas	Ethylene Oxide					+	+			+		+
	Paraformaldehyde			+	+	+	+		+	+		

Appendix D - Serum storage procedures

All personnel participating in the Serum Storage Program will be asked to sign the “Employee Serum Banking Program Consent/Declination Form” (available at ASU Employee Health) and provide a serum baseline donation as a recommended condition of participation in research, if the work involves any of the following:

- Human Immunodeficiency Virus, or HIV.
- *Mycobacterium tuberculosis*;
- Select agents or toxins;
- Microorganisms classified as Biosafety Level (BSL)-3/Animal Biosafety Level (ABSL)-3; and
- As recommended by the ASU Biosafety Officer, and/or the ASU Employee Health, and/or the IBC.

Principal Investigators or supervisors may also request for serum samples to be collected when research involves pathogenic, drug-resistant microorganisms, or microorganisms classified as BSL-2/ABSL-2.

Individuals choosing to decline to have a baseline serum sample drawn must sign the “Employee Serum Banking Program Consent/Declination Form” (available at ASU Employee Health).

A. Collection

A serum sample may be collected following an exposure (e.g., percutaneous or mucous membrane exposure to a body fluid, animal bite) to an infectious agent or other biohazardous material or at the conclusion of the work with the particular agent. Additional serum samples in addition to the baseline sample may be collected if requested by the individual or the supervisor based on a risk assessment or documented occupational exposure. These samples will not be processed through a clinical laboratory for the purposes of diagnostic reporting unless there is an occupational exposure. A new consent form must be obtained if additional serum is drawn.

B. Laboratory process

One 7 to 8.5 ml vial of blood will be obtained via venipuncture at ASU Employee Health. Becton-Dickinson tiger-top serum separator tubes should be used for this process. Once drawn, the specimen should be left to sit for 30 minutes. Subsequently, the clotted specimen should be centrifuged so that serum is separated from the cellular elements.

1. One milliliter (1 ml.) of serum is then pipetted into each of two cryo vial tubes with an O ring on top. These tubes should be labeled with a unique identification number rather than the worker’s personal information. This identifier will be linked with a log kept by ASU Employee Health that states the worker’s name and ASU ID number.
2. The two (2) labeled specimens will be divided into two freezers. ASU Employee Health personnel will place one sample in a -80°C freezer in ISTB-1 and another will be placed in a -80°C freezer in The Biodesign Institute.
3. The Serum Sample Log ([Attachment 1](#)) will be completed when entering and removing samples from the -80°C freezer.
4. The sera will be retained by ASU for purposes of this program for 30 years or for 10 years after the worker leaves the university.
 - a. ASU Employee Health will be responsible for compliance with all regulations related to the collection, storage, and release of medical information. Any information gained from testing a baseline serum sample will not be used for discrimination purposes or for any reason not

addressed in the consent.

- b. Specimens will be stored in accordance with recommendations of the American College of Clinical Pathologists by ASU Employee Health. The specimens will be stored at -80°C or lower, in two separate, secure and confidential freezers, maintained by DACT. The freezers are stored in a location with a back-up emergency generator. Storage of employee serum samples in laboratory freezers is not appropriate.

C. Storage and retrieval procedures

The Department of Animal Care and Technologies will 1) provide the space for the two freezers to include having them both on back-up power, 2) receive samples from ASU Employee Health, permit access to the ASU Employee Health staff for placement of one sample in each freezer, and 3) respond to any freezer failures by consolidating the samples into the remaining functional freezer until the failed freezer is functioning normal again.

ASU Employee Health will 1) ensure proper serum sample collection procedures are followed, 2) transfer samples to the secure -80°C freezers, and 3) complete the Serum Banking Log (Attachment 1).

ASU Employee Health will be permitted to release stored specimens in the following instances and only if appropriate consent has been obtained:

D. In the event of an exposure to an infectious or other biohazardous agent

Note: As stated above, the worker will be asked to sign a consent form allowing an aliquot of his or her serum to be released for testing.

E. Public Health Emergency

Note: The county or state health department may request information from ASU under such circumstances. For the purposes of public health emergencies, obtaining consent is not legally required.

and

If the worker requests that an aliquot of his/her sera be released to assist in providing medical care.

Note: A written request by the worker must be made in such situations.

Specimens obtained for the purposes of this program will become the property of ASU. Once the individual has provided the specimen, the individual will have no access to it unless there is a written request from a medical provider and the worker's signed consent.

F. Verification

1. Biosafety/Biosecurity staff will meet with representatives from ASU Employee Health and a representative from DACT to physically verify the serum sample inventory once a year.
2. Biosafety/Biosecurity staff will provide a report on the status of annual verification to the Director of Environmental Health and Safety, Associate Director of ASU Employee Health, and Director of DACT

Attachment 1 - ASU Serum Banking Log

Date	First and last name of person adding / removing sample	Time freezer opened	Sample ID #	Time freezer closed	Notes
2/5/ 2015	David Gillum	10:30am	2015-10000	10:35am	Sample added to bank